



Stator Sagging on Bulb Generators

Experience with air gap measurements on bulb and horizontal units has revealed that they are often prone to stator sagging in the section above the rotor. This is usually caused by weaknesses in the stator core-frame attachment system originating from design, manufacturing or assembly. This condition problem is considered progressive and expected to worsen with years due to constant gravitational forces acting on the overhanging section of the machine.

As the air gap diminishes from gravity in the upper section, magnetic pull increases exponentially. In turn, this magnetic imbalance aggravates the problem by producing cyclic strains on the rotor components, and stress on the stator. In the short or long term, these may affect the behavior of generator by inducing vibration, overheating, fatigue, and present risk of failure, breakdown and rub.

The bulb unit in Figure 1 is a typical example. The stator has severely deformed by adopting an oval shape. The stator roundness is well beyond the critical tolerance². This condition is considered alarming and abnormal.

The weakness seems to come from design or manufacturing, not from machine erection, as the deformation is uniform and similar on other units of the plant. As much as the bracing system fails to support the upper section of the stator, it allows the stator to move outward laterally. This flexing is so consistent that stator concentricity barely changes.

Continuous trend and alarm monitoring of the main air gap parameters is highly recommended on bulb and horizontal generators.

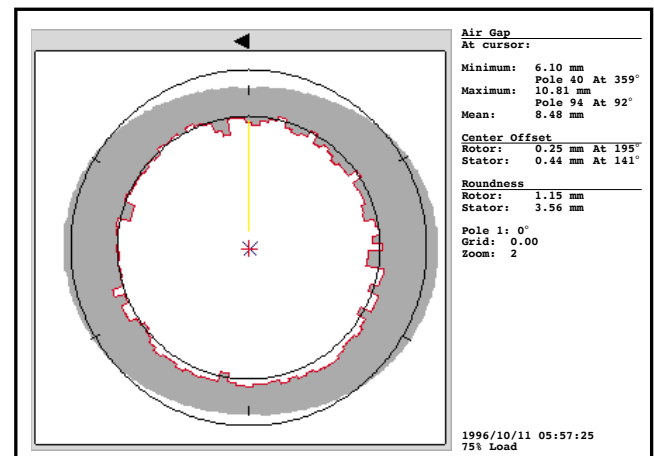

Figure 1: Polar view of bulb unit generator showing stator sagging.

1 Percentage over nominal air gap value.

2 "Mechanical Tolerances Guidelines for Hydroelectric Generators" (Application Note AN001).

For more information, contact VibroSystM at:
2727 East Jacques-Cartier Blvd
Longueuil (Quebec) J4N 1L7 CANADA
Tel.: +1 450 646-2157 • +1 800 663-8379 (US only)
Fax: +1 450 646-2164
Email: sales@vibrosystem.com
www.vibrosystem.com