



PCS™-302

CAPACITIVE PROXIMITY SENSOR

GENERAL SPECIFICATIONS

Operation

• Measurement type	Non-contact proximity, capacitive technology
• Measuring range	0.3 to 2.3 mm [11.8 to 90.6 mils]
• Output	4 to 20 mA
• Sensitivity	8 mA/mm [0.2 mA/mil]
• Accuracy	± 1.25% FSR (calculated on a full scale range)
• Repeatability	± 0.5% FSR (calculated on a full scale range)
• Residual noise	± 50 µm (at mid-range)
• Bandwidth	0 to 1000 Hz (-3dB)
• Load at current output	500 Ω max.
• Temperature drift	< 350 ppm/°C (at mid-range)
• Short circuit protection	Built-in

Power Requirements

• Voltage	24 Vdc ± 15%
• Consumption	60 mA max.
• Voltage reversal protection	Built-in
• Warm-up time	5 minutes

Connection

• Connector type	5-position M12 male
• Max. cable length	300 m [984 ft]

Environment

• Temperature range	
Operating	0 to 60°C [32 to 140°F]
Storage	-25 to 70°C [-13 to 158°F]
• Humidity	Up to 95%, non-condensing

Physical Characteristics

• Sensor body	Nickel-plated brass
• Sensing face	Glass-reinforced laminate

DIMENSIONS

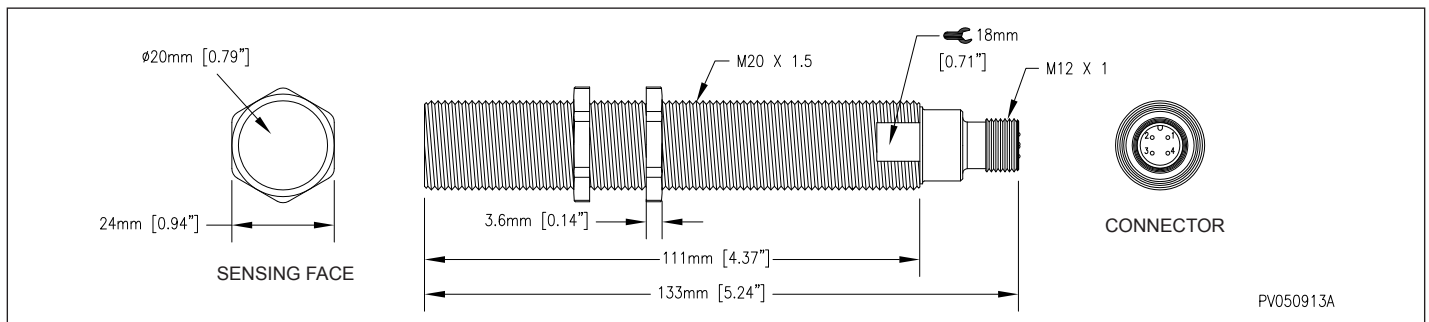

PRODUCT IDENTIFICATION

Product Number	Description
VSM-PCS302	PCS-302 Capacitive Proximity Probe with built-in signal conditioner (0.3-2.3 mm)

Publication: 2019-08-13