

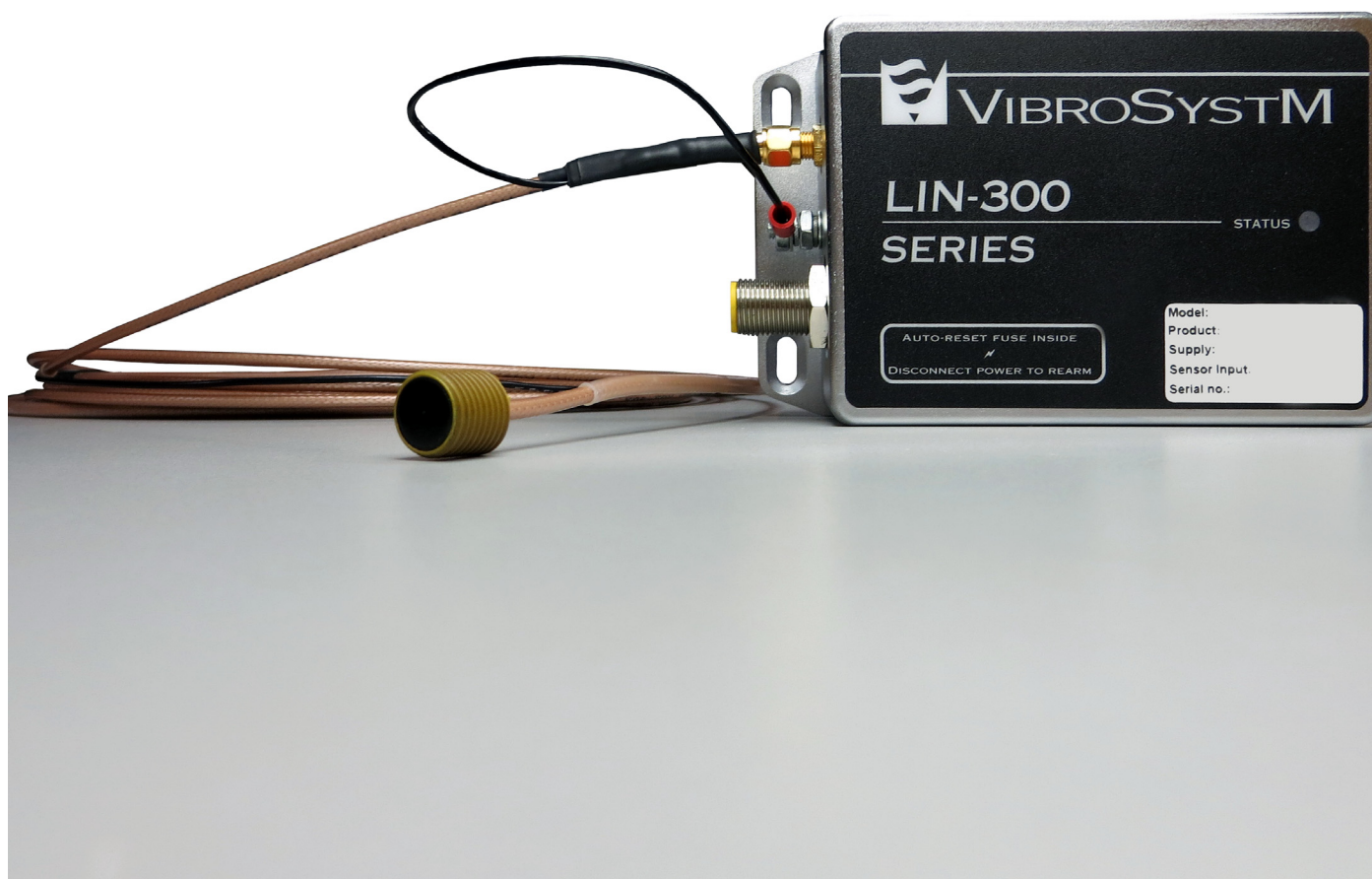

SBVTM-202P

Stator Bar Vibration Measuring Chain

User's Manual







Safety Information

The following manual contains information and warnings. They must be followed in order to keep the instrument in a working condition and ensure safe operation.

Safety and Electrical Symbols

	Warning - Danger - Identifies conditions or practices that could cause physical harm or death.
	Caution - Identifies conditions or practices that could result in a permanent loss of data or damage the measuring chain and/or other equipment to which it is connected.
	Important Information - Identifies important information, hints, and tips that must be read and applied.

Safety Precautions

 **Warning - Danger**  **Caution**

- To use the described product correctly and safely, read and follow all safety instructions or warnings that appear throughout this manual.
- This product is intended to be used by qualified operators and maintenance personnel who recognize shock hazards and are familiar with the safety precautions required to avoid possible injury. Read and follow all installation, operation, and maintenance information before using this product.
- Install and use this product only as specified in this manual or the protection provided by this product might be impaired.
- When in doubt that safety protection has been impaired, make this product inoperative and secure it against any unintended operation.
- Use caution when working with voltage levels above 30 VAC RMS or 42 VDC. These voltage levels are potential shock hazards.
- Follow all generally accepted safety practices and procedures when working with or around electricity.
- Do not use this product in wet environments.

The VibroSystM logo, SBV™, and LIN™ are registered trademarks or trademarks of VibroSystM Inc.

This manual is provided solely for guidance. VibrosystM Inc. takes no responsibility or liability for any damage caused by accidents, improper installation or misuse. Liability is limited to the repair and/or replacement of defective products.

VibroSystM Inc. 2727 Jacques-Cartier E. Blvd, Longueuil, QC, Canada J4N 1L7 | Phone: 450 646-2157 | U.S. Toll-free Line: 800 663-8379

Email: techsupp@vibrosystm.com | www.vibrosystm.com



TABLE OF CONTENTS

1. SBV-202P MEASURING CHAIN OVERVIEW	5
1.1 Description	5
1.2 Main Unit Interventions	5
2. SBV-202P SENSOR INSTALLATION OVERVIEW	6
2.1 Preliminary Considerations	6
2.2 Typical Sensor installation	7
3. LIN-300 SERIES CONDITIONER OVERVIEW	8
3.1 Description	8
4. LIN-300 SERIES INSTALLATION OVERVIEW	8
4.1 Preliminary Considerations	8
4.2 Typical LIN-300 Installation	9
4.3 M12 Connector Pinout	10
4.4 Grounding the Signal Cable's Shield	10
4.5 Output Signal Value	10
5. LIN-300 SERIES CONDITIONER OPERATION	11
5.1 Boot Sequence	11
5.2 LED Functionality	11





1. SBV-202P MEASURING CHAIN OVERVIEW

1.1 Description

The SBV-202P measuring chain is designed for non-contact measurements of stator winding vibration. To achieve this, a hole is bored directly into the wedge of a high voltage bar. Then, an SBV-202P vibration sensor is installed into the hole to measure the distance to the bar. The information is transferred into a LIN[™]-300 series conditioner through the sensor's integral cable and the entire chain is then connected to the ZPU[™]-5000 acquisition unit through an M12 connector and signal cable.

SBV-202P Capacitive Vibration Sensor

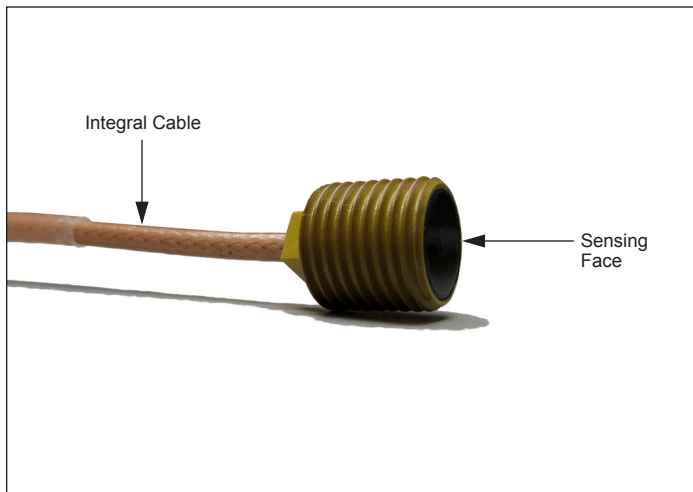

Important Information

- SBV-202P sensors cover a 0.3 to 2.3 [12 to 91 mils] measuring range.

Measuring Chain and Signal Cable Layout

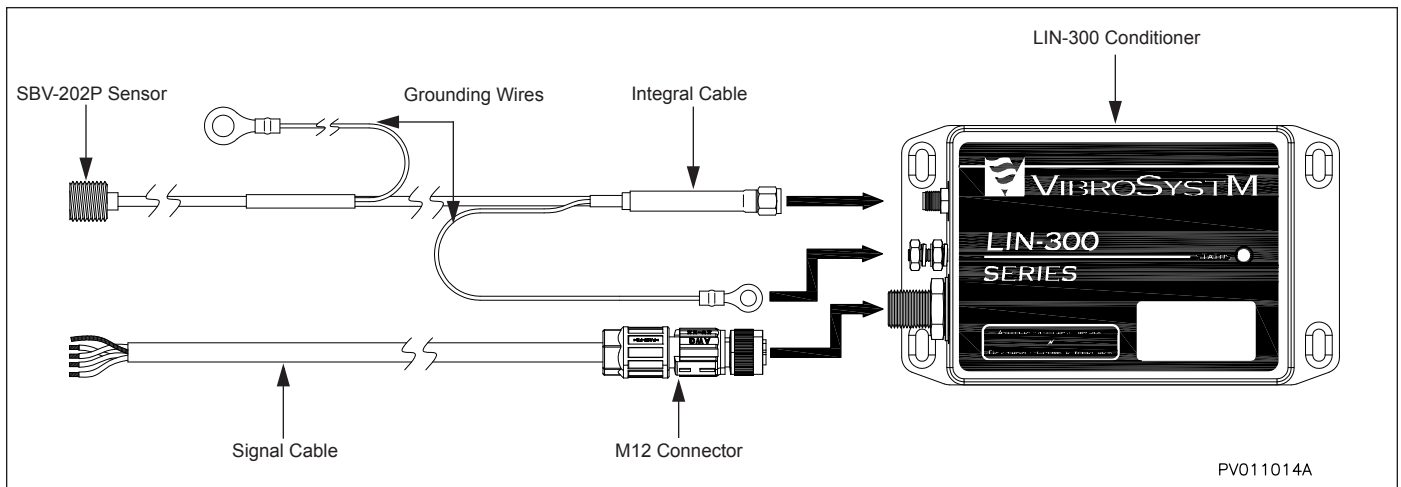

1.2 Main Unit Interventions

- A hole must be threaded in the wedge to position the sensor.
- A hole must be threaded in the stator core pressure plate to connect the integral cable's grounding wire on the sensor side.
- A protection box (or more) must be installed outside the stator core to house the LIN conditioner(s).
- Protective conduits must be routed throughout the unit to protect the cables.



2. SBV-202P SENSOR INSTALLATION OVERVIEW

Important Information

- VibroSystM technicians should be present during measuring chain installation and commissioning.

2.1 Preliminary Considerations

- Holes must be threaded into the wedge assembly to receive the sensors.
- Possible sensor locations are limited by the integral cable's maximum length and the conditioner's position.
- To prevent vibration wear, cable clamps, glue, and epoxy must be used to secure the cables into place.

Caution

- Do not apply paint or silicone on the sensor's sensing face.
- Never exert traction on the cable or connector.
- Integral cables are factory calibrated and must **NEVER** be cut or altered.
- Grounding wires must **NEVER** be cut or altered.



2.2 Typical Sensor installation

The illustration below represents a typical overview of a machined wedge assembly.

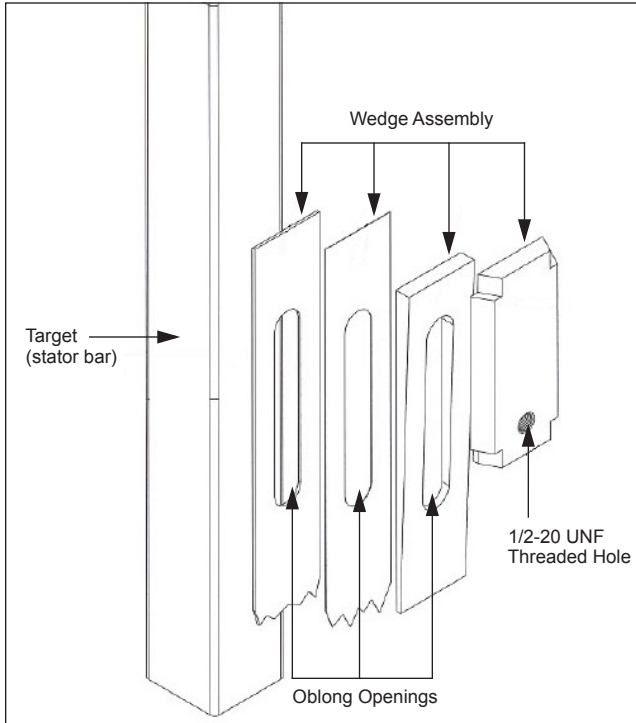

! Important Information

- The oblong opening through the wedge assembly must be long enough to allow an unobstructed view of the target (stator bar). It offers a vertical tolerance for component positioning.

The illustration below is a typical lateral cut-up view of an SBV-202P sensor properly installed into a wedge.

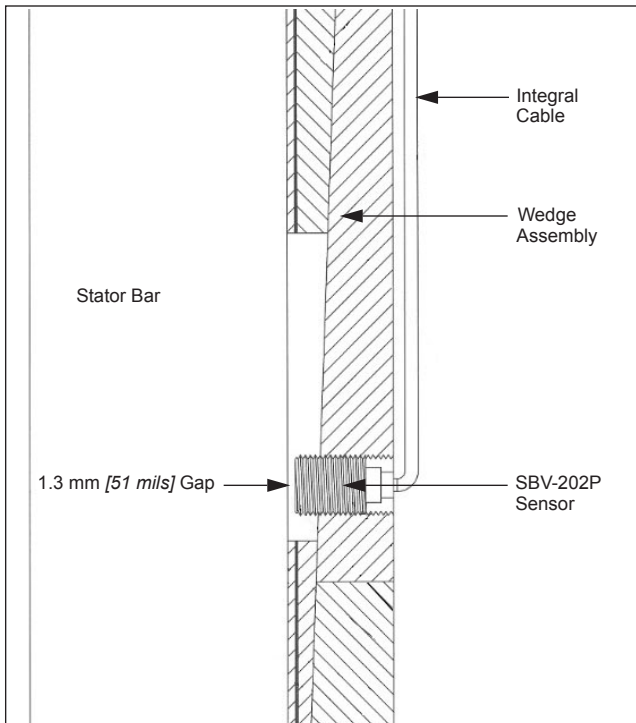

! Caution

- The integral cable at the sensor end must be grounded to the stator core's pressure plate.



3. LIN-300 SERIES CONDITIONER OVERVIEW

3.1 Description

The LIN-300 series conditioners are signal conditioning units which, when paired with matching sensors, deliver a 4 to 20 mA linearized raw output signal. Sensors are connected to the conditioner through an SMA connector, while power input and signal output are provided by a signal cable through an M12 connector.

LIN-300 Series Conditioner



4. LIN-300 SERIES INSTALLATION OVERVIEW

4.1 Preliminary Considerations

- The LIN-300 must be installed in a properly grounded protection box and mounting panel.
- The power/signal cable is limited to a maximum length of 300 m [984 ft].
- Possible conditioner locations are limited by the length of the sensor's integral cable.

Caution

- It is recommended to use a VibroSystM protection box since it is equipped with vibration dampers and offers excellent grounding. Using a generic box could affect the entire measuring chain's performance.



4.2 Typical LIN-300 Installation

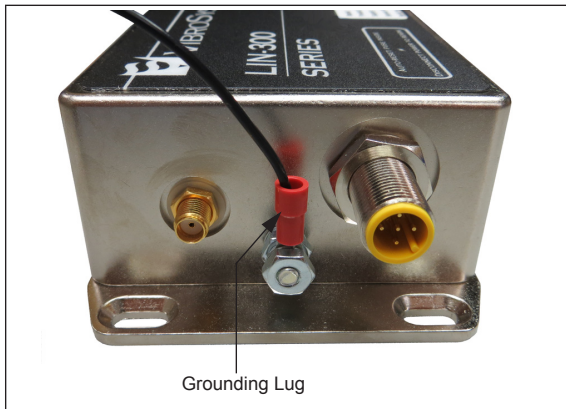

1. Make sure the grounding lug is firmly secured to the LIN-300's grounding terminal.

Recommended torque: 1.7 Nm [15 in-lb]

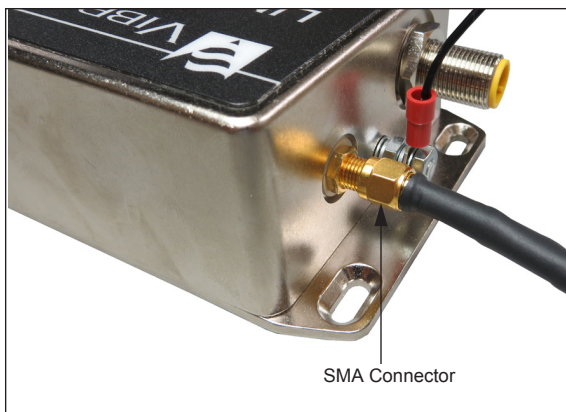

2. Make sure the integral cable's SMA connector is firmly secured to the LIN-300's SMA socket.

Recommended torque: 1.1 Nm [10 in-lb]

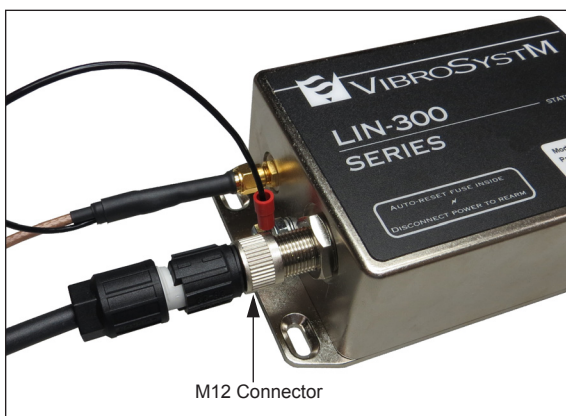

3. Make sure the M12 connector is firmly secured in place.

Caution

- Grounding is achieved through the LIN-300's four installation screws.



4.3 M12 Connector Pinout

The illustration below shows the LIN-300's M12 male connector pinout.

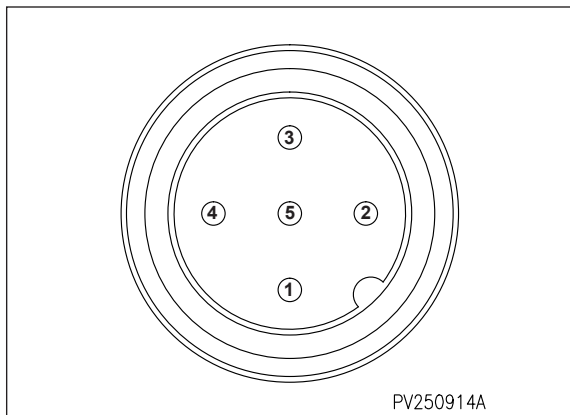

The table below shows the color codes, designations and specifications for VibroSystM's signal cable.

M12 Connector Pin #	Corresponding Color Code	Designation	Specifications
1	Brown	Power Supply	+24 VDC
2	White	Current Output	4-20 mA (proportional to sensor's full range)
3	Blue	Common	0 V
4	Black	Not Used	
5	Not Used		

4.4 Grounding the Signal Cable's Shield

The signal cable's shield must also be grounded. It is important that the shield be grounded on one end only to avoid creating a ground loop. If the M12 connector at the end of the signal cable is insulated from the shield, the shield must then be grounded on the acquisition unit side. However, if the M12 connector at the end of the signal cable is connected to the shield, connecting the signal cable to an already grounded LIN-300 conditioner will automatically ground the shield. In this case, the shield must not be grounded on the acquisition unit side.

4.5 Output Signal Value

Once the sensor is connected, the LIN-300's output signal value must be within the 3 to 22 mA range. The output signal provides linear current throughout the entire measuring range. The distance value is obtained by applying the following transfer formula:

LIN-302VP-6I-0.3/2.3

- $D_{mm} = (I_{out}(mA) - 1.60) / 8$ Over 4-20 mA Output
- $D_{mils} = (I_{out}(mA) - 1.57) / 0.202$ Over 4-20 mA Output



5. LIN-300 SERIES CONDITIONER OPERATION

5.1 Boot Sequence

Once the sensor is connected, apply power to the LIN-300 and verify the 3-color LED indicator's flash sequence upon start-up. A normal boot sequence should be as follows:

One orange flash, followed by green flashes.

5.2 LED Functionality

Once the boot sequence is completed, the LED indicator will continue flashing green while the LIN-300 scans the measuring chain. Once the scan is completed, the LED reflects the chain's overall condition:



Continues Flashing Green: Indicates a normal operation (Status OK).

Flashes Red: Indicates an error condition. Two flash sequences are most likely to occur:

Error Condition #1: The LED turns on for one second, followed by one brief flash. This means that the sensor is not connected.

Error Condition #2: The LED turns on for one second, followed by two brief flashes. This means that the sensor's distance to the target is below the minimum detection range.

If a different LED sequence from the ones explained above appears on the LIN-300, please contact VibroSystem.

