



DIBUJOS TÉCNICOS DEL SISTEMA ZOOM - Industrias mineras

El objetivo principal de estos dibujos completos del sistema es proporcionar al cliente una representación de todo el sistema de monitoreo ZOOM. Todo comienza con la instalación de los sensores, seguido del cableado para finalmente llegar al gabinete de instrumentación y la conexión al servidor ZOOM. También incluye todas las interacciones con los sistemas de control del cliente (SCADA, PLC, red corporativa, etc...). También es una referencia que se utiliza para guiar a todas las partes involucradas durante la instalación, tanto para la planificación y ejecución de obras. Cuando se considere que la instalación está completa, los dibujos completos del sistema se convertirán en la referencia a largo plazo para recordar cómo se instala el sistema de monitoreo ZOOM.

CARACTERÍSTICAS PRINCIPALES DE LOS DIBUJOS

- El contenido de los dibujos está agrupado por especialidades para dividir fácilmente el trabajo
- Se proporciona una primera versión en las primeras etapas de la instalación con fines de planificación
- Se ofrecen actualizaciones de planos durante las distintas etapas de instalación y puesta en servicio
- Se proporcionará una versión final al finalizar la instalación y la puesta en servicio

Secciones de dibujos y contenido detallado.

Sección	Descripción
A. Diagramas de alto nivel y detalles de red.	Incluye la disposición general, incluida la descripción general del sistema, el diagrama de flujo del sistema, el diagrama de bloques y, finalmente, el diseño de la red.
B. Ubicaciones de cadenas de medición y detalles de instalación	Incluye detalles de instalación para cada sensor, incluida la vista general del molino con ubicación del sensor, detalles de instalación y vista aproximada del sensor.
C. Mecánico	Incluye los detalles de instalación de cada componente mecánico, es decir dimensiones, holgura, anclaje del gabinete y montaje de todo tipo de cajas de conexiones.
D. Cableado	Incluye el cableado detallado para la conexión de todas las cadenas de medición, desde cada sensor hasta la conexión dentro del gabinete de instrumentación.
E. Componentes internos y cableado del gabinete de monitoreo ZOOM	Incluye los diseños de equipos y también se incluyen descripciones generales de cada ZPU-5000. También incluye el esquema eléctrico detallado del armario.
F. Caja de conexiones (WME) componentes internos y cableado	Incluye el detalle de gabinetes y cajas, mostrando la ubicación de cada acondicionador de señal y la asignación de los bloques de terminales.

INFORMACIÓN DEL PRODUCTO

Número de producto	Descripción
VSM-STDWG/M	Sistema ZOOM - Dibujos técnicos - Paquete Completo

Apéndice: Ejemplo de dibujos técnicos del sistema ZOOM

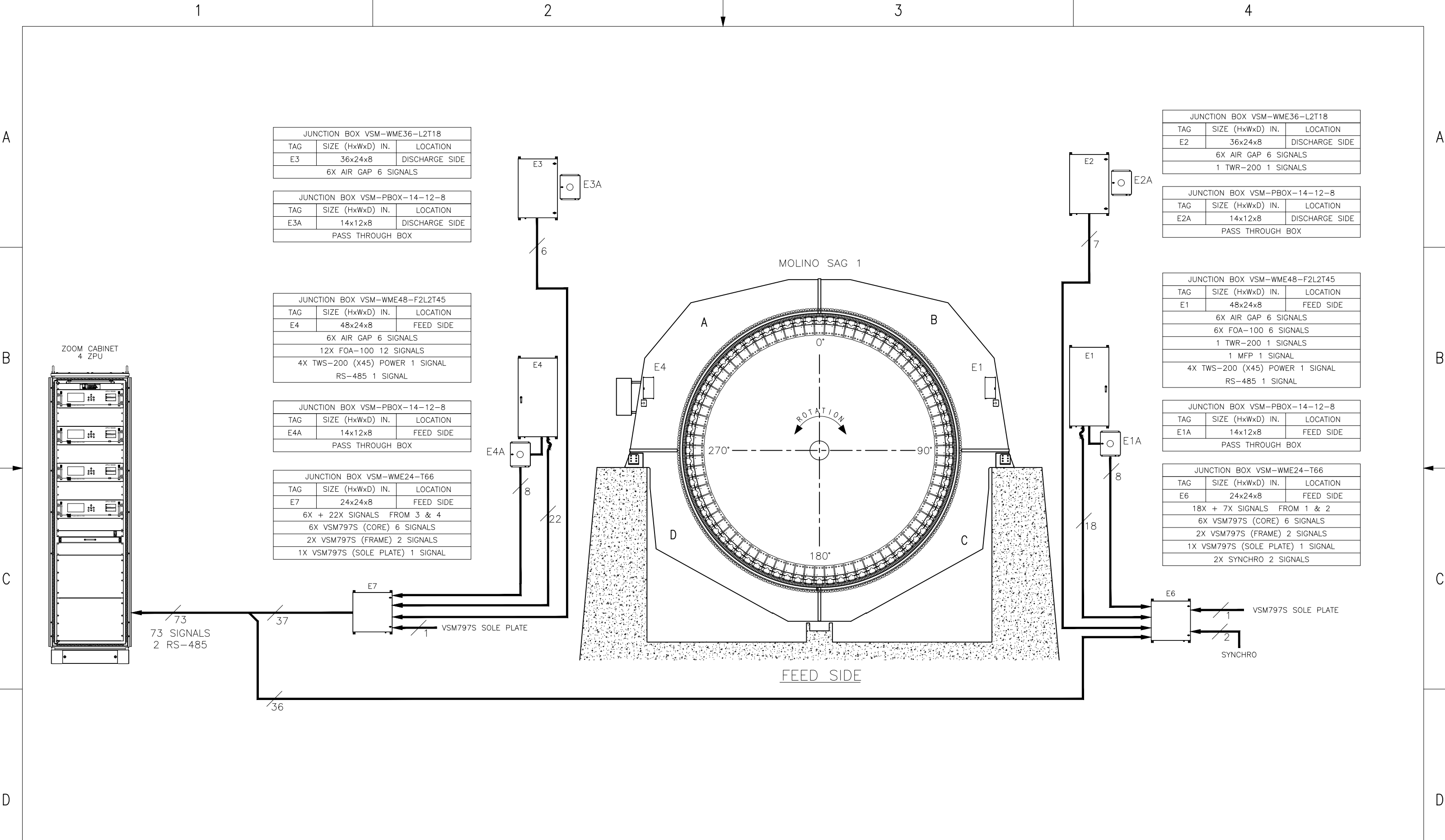

JUNCTION BOX VSM-WME36-L2T18		
TAG	SIZE (HxWxD) IN.	LOCATION
E3	36x24x8	DISCHARGE SIDE
6X AIR GAP 6 SIGNALS		

JUNCTION BOX VSM-PBOX-14-12-8		
TAG	SIZE (HxWxD) IN.	LOCATION
E3A	14x12x8	DISCHARGE SIDE
PASS THROUGH BOX		

JUNCTION BOX VSM-WME48-F2L2T45		
TAG	SIZE (HxWxD) IN.	LOCATION
E4	48x24x8	FEED SIDE
6X AIR GAP 6 SIGNALS		
12X FOA-100 12 SIGNALS		
4X TWS-200 (X45) POWER 1 SIGNAL		
RS-485 1 SIGNAL		

JUNCTION BOX VSM-PBOX-14-12-8		
TAG	SIZE (HxWxD) IN.	LOCATION
E4A	14x12x8	FEED SIDE
PASS THROUGH BOX		

JUNCTION BOX VSM-WME24-T66		
TAG	SIZE (HxWxD) IN.	LOCATION
E7	24x24x8	FEED SIDE
6X + 22X SIGNALS FROM 3 & 4		
6X VSM797S (CORE) 6 SIGNALS		
2X VSM797S (FRAME) 2 SIGNALS		
1X VSM797S (SOLE PLATE) 1 SIGNAL		

JUNCTION BOX VSM-WME36-L2T18		
TAG	SIZE (HxWxD) IN.	LOCATION
E2	36x24x8	DISCHARGE SIDE
6X AIR GAP 6 SIGNALS		
1 TWR-200 1 SIGNALS		

JUNCTION BOX VSM-PBOX-14-12-8		
TAG	SIZE (HxWxD) IN.	LOCATION
E2A	14x12x8	DISCHARGE SIDE
PASS THROUGH BOX		

JUNCTION BOX VSM-WME48-F2L2T45		
TAG	SIZE (HxWxD) IN.	LOCATION
E1	48x24x8	FEED SIDE
6X AIR GAP 6 SIGNALS		
6X FOA-100 6 SIGNALS		
1 TWR-200 1 SIGNALS		
1 MFP 1 SIGNAL		
4X TWS-200 (X45) POWER 1 SIGNAL		
RS-485 1 SIGNAL		

JUNCTION BOX VSM-PBOX-14-12-8		
TAG	SIZE (HxWxD) IN.	LOCATION
E1A	14x12x8	FEED SIDE
PASS THROUGH BOX		

JUNCTION BOX VSM-WME24-T66		
TAG	SIZE (HxWxD) IN.	LOCATION
E6	24x24x8	FEED SIDE
18X + 7X SIGNALS FROM 1 & 2		
6X VSM797S (CORE) 6 SIGNALS		
2X VSM797S (FRAME) 2 SIGNALS		
1X VSM797S (SOLE PLATE) 1 SIGNAL		
2X SYNCHRO 2 SIGNALS		

CADREBH2023revB



© Copyright VibroSystM inc.2023
 VibroSystM inc. reserves the right to make changes without prior notice to improve the product.

Section: A	HIGH LEVEL DIAGRAMS & NETWORK DETAILS		Title: ZOOM MONITORING SYSTEM PROJECT: YOUR MINING SITE SYSTEM OVERVIEW	
Product number: VSM-CAB-MINE1-100	Drawing number: VSM-DWG-MINE1-100	Sheet: A1	Rev. : 1	

1 2 3 4

A A





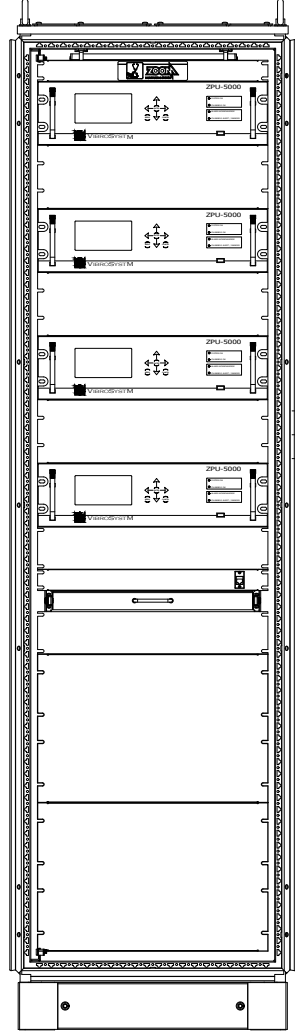

B B

C C





D D

VIBROSYSTEM ZOOM
MONITORING CABINET

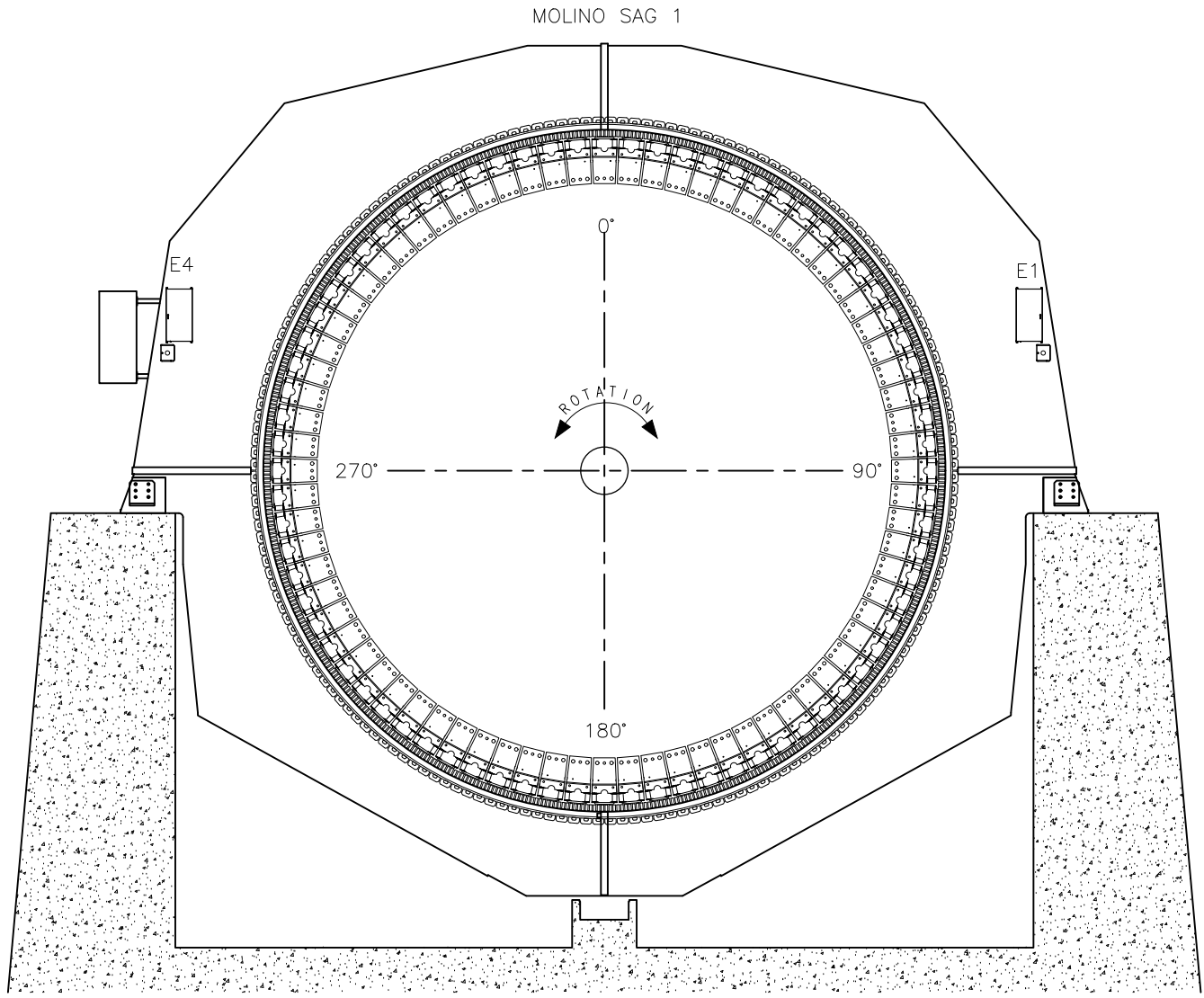

- VM-GMD (24X) 
- MFP-100 (1X) 
- TWR-200 (2X) 
- FOA-100 (18X) 
- VSM797S (18X) 
- SYNCHRO (2X) 
- TWS-200 (360X) 



- LEGEND**
-  AIR GAP (VM-GMD)
 -  MAGNETIC FLUX
 -  ABSOLUTE VIBRATION
 -  TEMPERATURE TWS
 -  SYNCHRO

FEED SIDE

CADREH2023revB



© Copyright VibroSystM inc.2023
VibroSystM inc. reserves the right to make changes without prior notice to improve the product.

Section: A	HIGH LEVEL DIAGRAMS & NETWORK DETAILS		Title: ZOOM MONITORING SYSTEM PROJECT: YOUR MINING SITE	
Product number: VSM-CAB-MINE1-100	Drawing number: VSM-DWG-MINE1-100	Sheet: A2	Rev. : 1	FLOW CHART

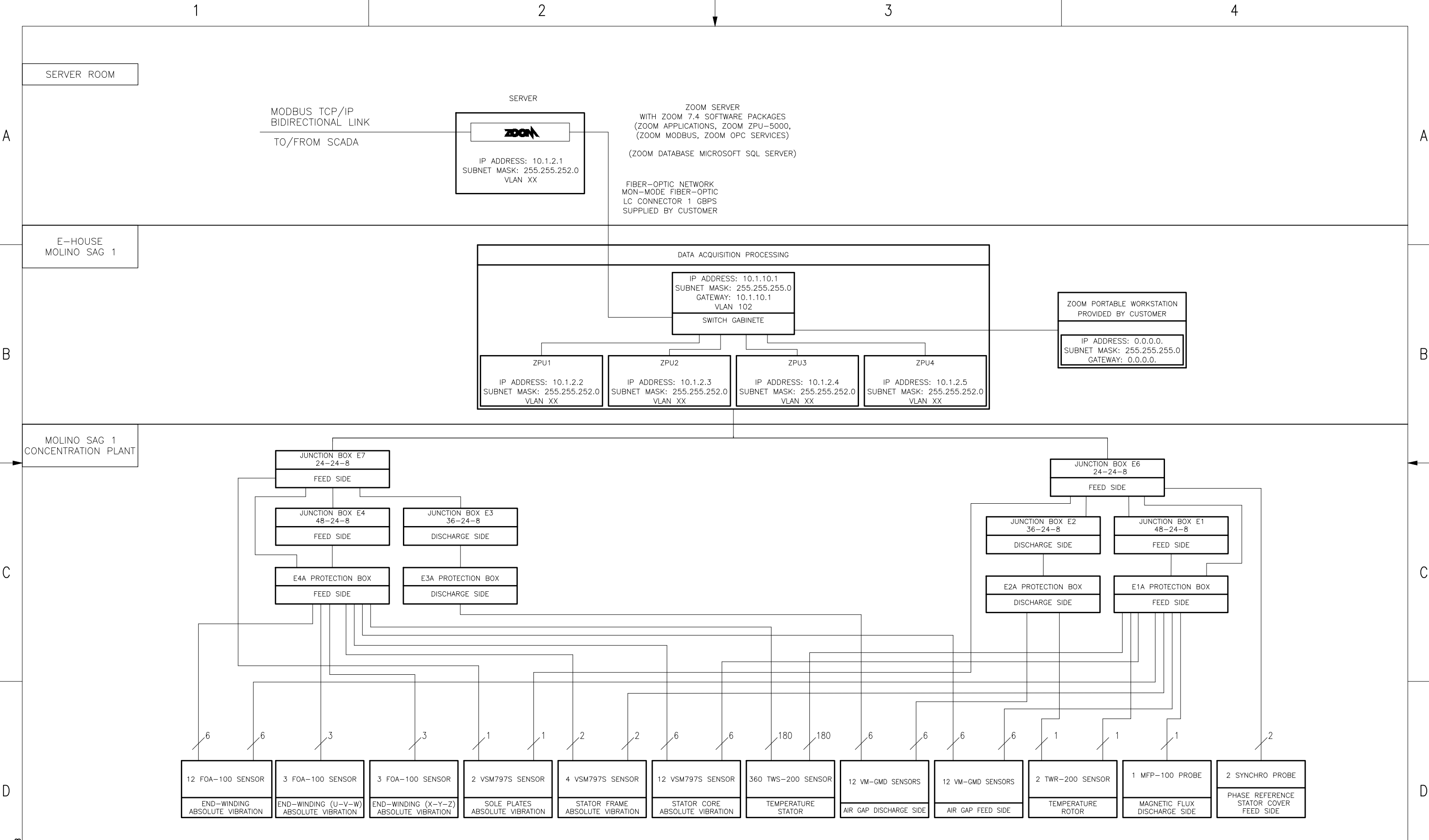

CADREB2023revB



© Copyright VibroSystM inc.2023
 VibroSystM inc. reserves the right to make changes without prior notice to improve the product.

Section: A HIGH LEVEL DIAGRAMS & NETWORK DETAILS
 Product number: VSM-CAB-MINE1-100
 Drawing number: VSM-DWG-MINE1-100
 Sheet: A3 Rev.: 1

Title: ZOOM MONITORING SYSTEM PROJECT: YOUR MINING SITE
 BLOCK DIAGRAM

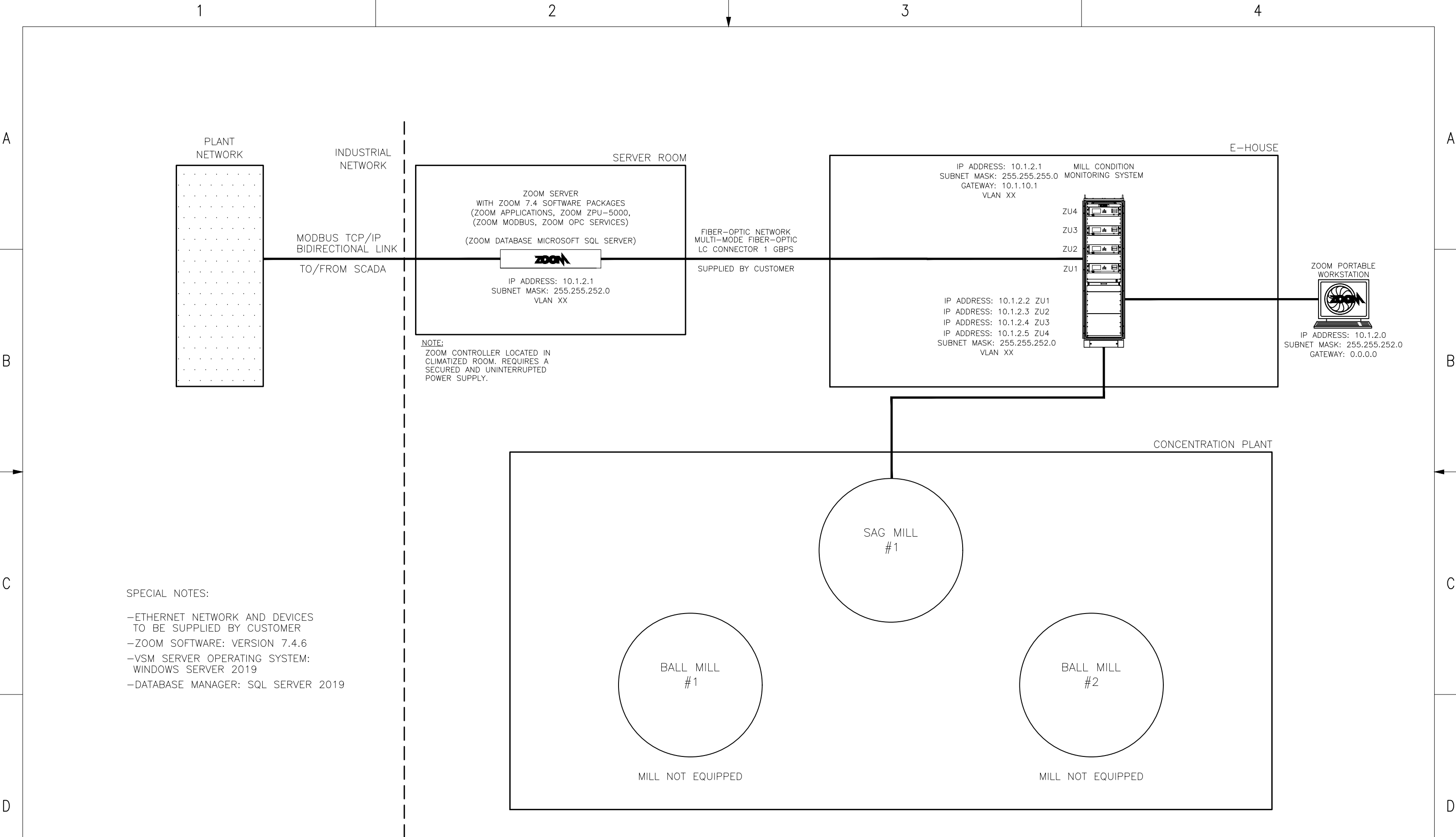

CADREB2023revB



© Copyright VibroSystM inc.2023
VibroSystM inc. reserves the right to make changes without prior notice to improve the product.

Section: A	HIGH LEVEL DIAGRAMS & NETWORK DETAILS		Title: ZOOM MONITORING SYSTEM PROJECT: YOUR MINING SITE NETWORK LAYOUT	
Product number: VSM-CAB-MINE1-100	Drawing number: VSM-DWG-MINE1-100	Sheet: A4	Rev. : 1	

1

2

3

4

A

A

B

B

C

C

D

D

SENSOR DETAILS				
SENSOR #	MESURING AXIS	ANGLE	SLOT #	VIEW
AG1	RADIAL	5	31	B
AG2	RADIAL	43	88	B
AG3	RADIAL	85	152	B
AG4	RADIAL	95	166	B
AG5	RADIAL	133	223	B
AG6	RADIAL	175	287	B
AG7	RADIAL	185	301	B
AG8	RADIAL	223	358	B
AG9	RADIAL	265	422	B
AG10	RADIAL	275	436	B
AG11	RADIAL	313	493	B
AG12	RADIAL	355	17	B
MFP1	RADIAL	80	144-145	A

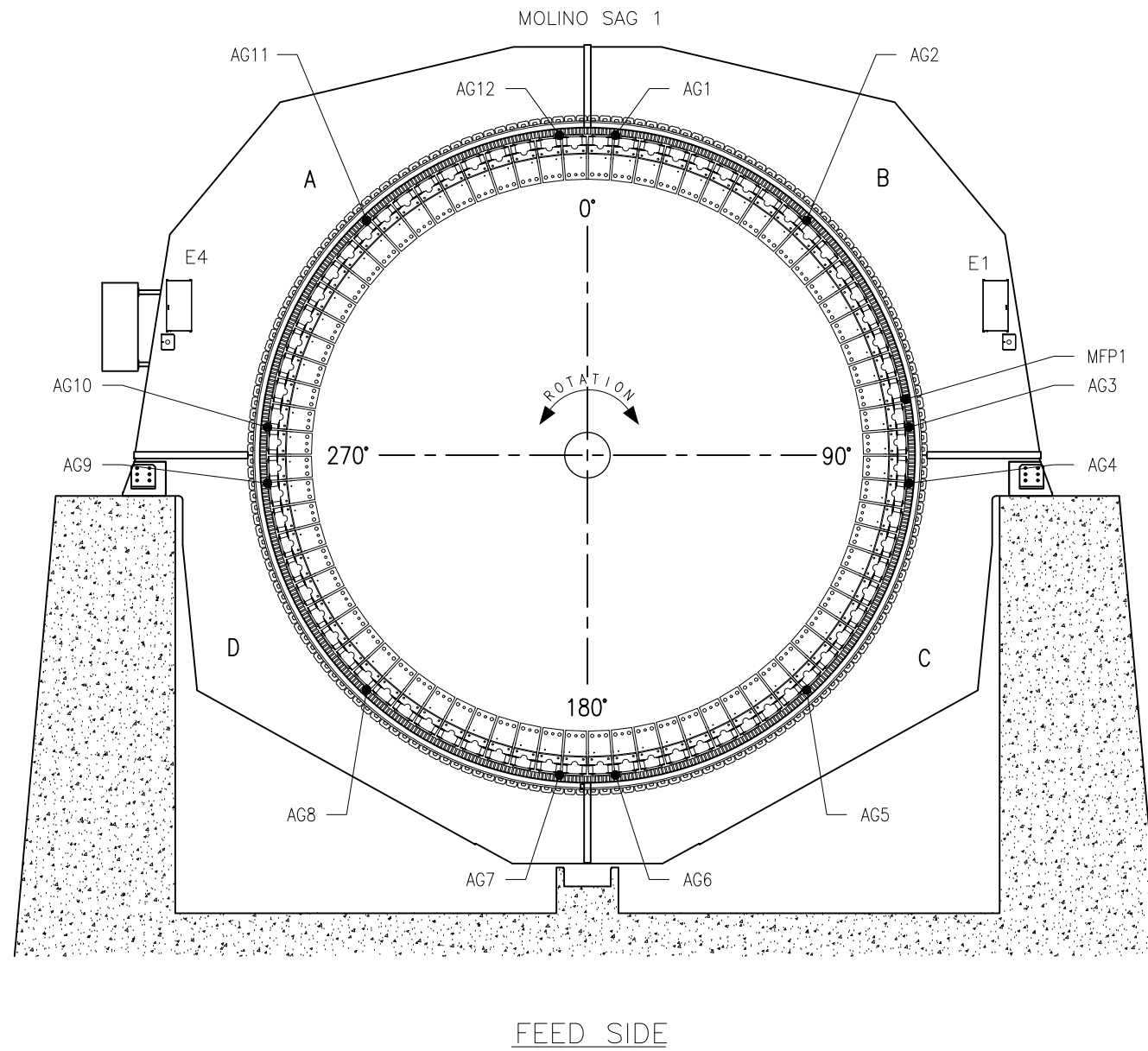

SENSOR'S TOP MUST BE
1-2 cm LOWER THAN
THE POLE MAGNETIC
CORE EXTREMITY
(SEE BELOW)

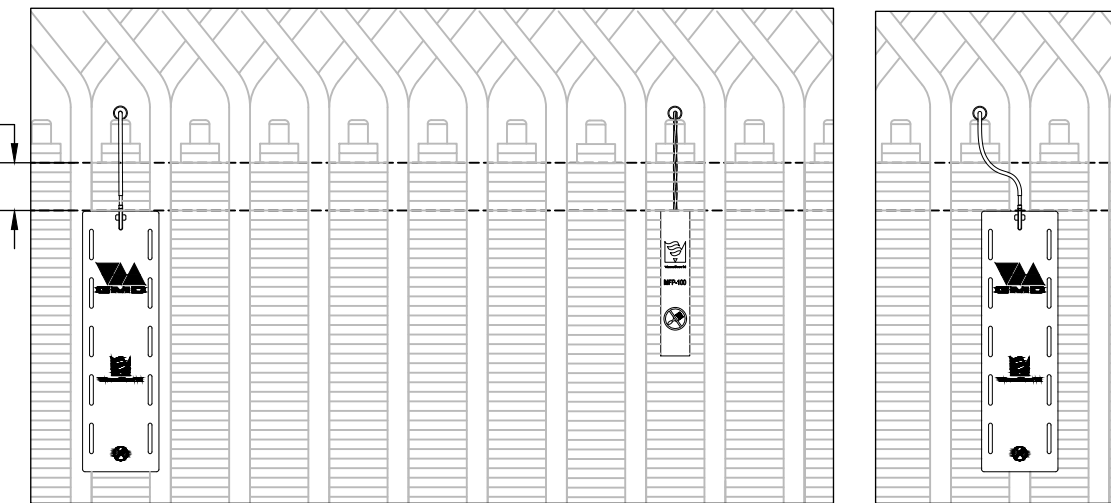

VIEW "A"

VIEW "B"

VM-GMD /MFP-100 LOCATION FRONT VIEW

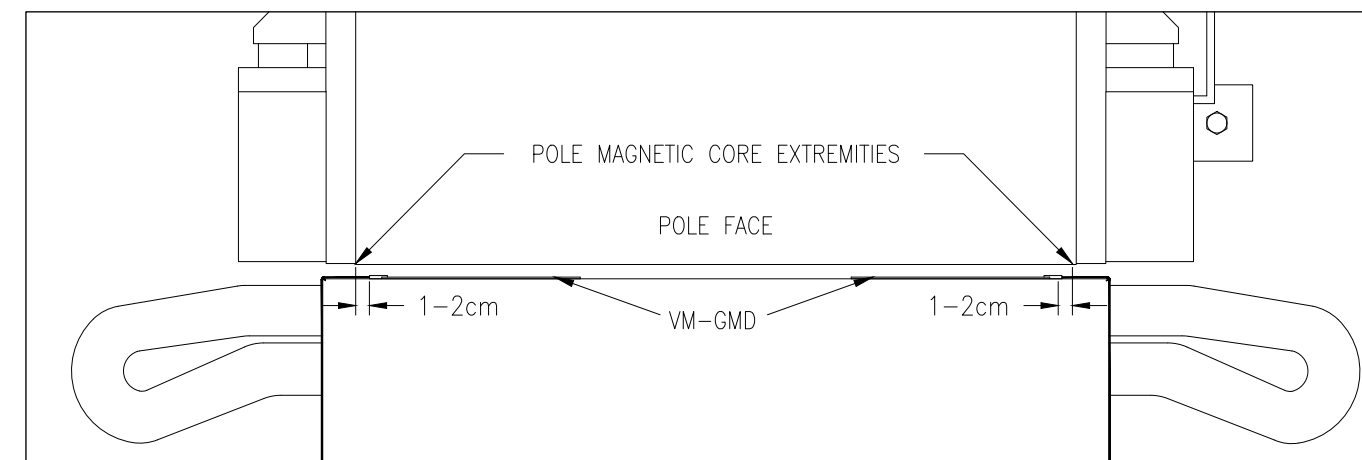

VM-GMD LOCATION SIDE VIEW

CADREB2023revB



© Copyright VibroSystM inc.2023
VibroSystM inc. reserves the right
to make changes without prior
notice to improve the product.

Section: B MEASURING CHAINS LOCATIONS & INSTALLATION DETAILS
Product number: VSM-CAB-MINE1-100
Drawing number: VSM-DWG-MINE1-100
Sheet: B1 Rev.: 1

Title: ZOOM MONITORING SYSTEM FOR PROJECT: YOUR MINING SITE
AIR GAP & MAGNETIC FLUX SENSORS DETAILS FEED SIDE

1

2

3

4

1

2

3

4

A

A

B

B

C

C

D

D

SENSOR DETAILS				
SENSOR #	MESURING AXIS	REAL ANGLE	SLOT #	VIEW
AG13	RADIAL	5	31	B
AG14	RADIAL	43	88	B
AG15	RADIAL	85	152	B
AG16	RADIAL	95	166	B
AG17	RADIAL	133	223	B
AG18	RADIAL	175	287	B
AG19	RADIAL	185	301	B
AG20	RADIAL	223	358	B
AG21	RADIAL	265	422	B
AG22	RADIAL	275	436	B
AG23	RADIAL	313	493	B
AG24	RADIAL	355	17	B

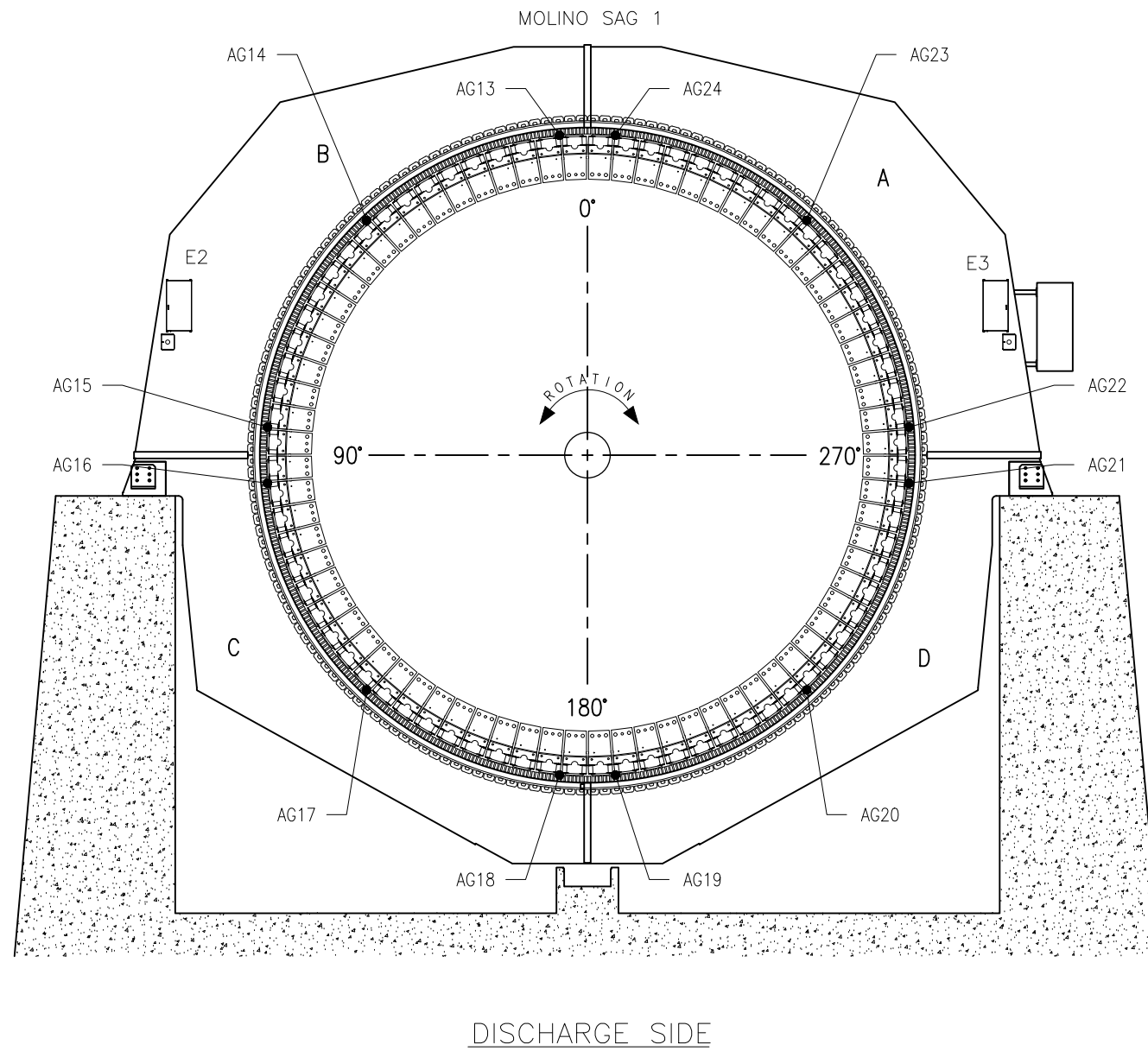

SENSOR'S TOP MUST BE
1-2 cm LOWER THAN
THE POLE MAGNETIC
CORE EXTREMITY
(SEE BELOW)

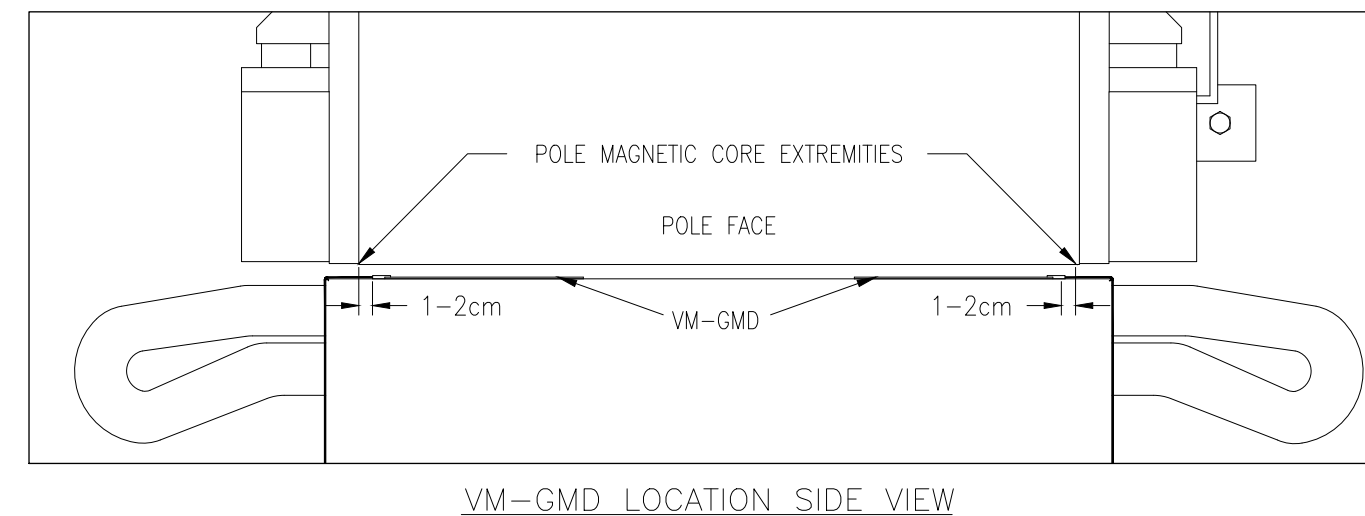
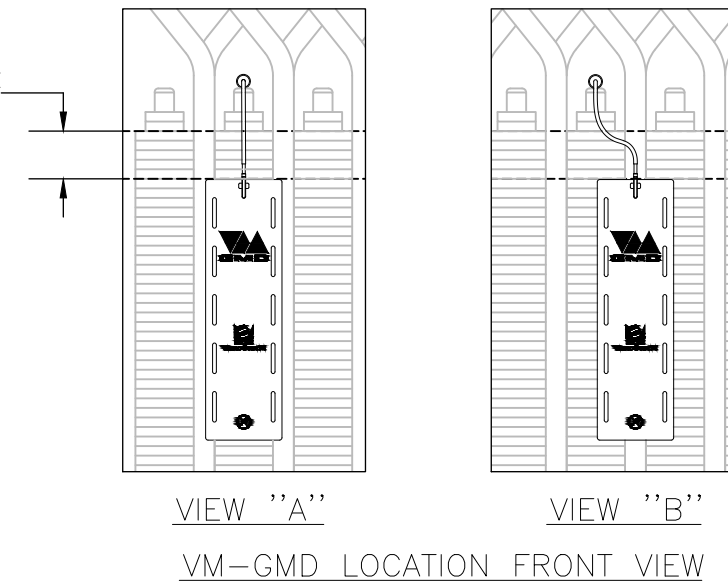

CADREB/2023revB



© Copyright VibroSystM inc. 2023
VibroSystM inc. reserves the right
to make changes without prior
notice to improve the product.

Section: B MEASURING CHAINS LOCATIONS & INSTALLATION DETAILS

Product number: VSM-CAB-MINE1-100 Drawing number: VSM-DWG-MINE1-100 Sheet: B2 Rev.: 1

Title: ZOOM MONITORING SYSTEM FOR PROJECT: YOUR MINING SITE
AIR GAP & MAGNETIC FLUX SENSORS DETAILS DISCHARGE SIDE

1

2

3

4

SENSOR DETAILS				
SENSOR #	MESURING AXIS	SLOT #	SLOT ANGLE	BAR #
FOA1	RADIAL	474	300-LINE	477U
FOA2	RADIAL	365	227-LINE	368V
FOA3	RADIAL	455	287-LINE	458W
FOA4	RADIAL	410	257-NEUTRAL	413X
FOA5	RADIAL	429	270-NEUTRAL	432Y
FOA6	RADIAL	519	330-NEUTRAL	522Z
FOA7	RADIAL	301	185	303W
FOA8	RADIAL	358	223	361V
FOA9	RADIAL	422	265	425V
FOA10	RADIAL	436	275	438Z
FOA11	RADIAL	493	313	496Z
FOA12	RADIAL	17	355	20V
FOA13	RADIAL	31	5	34W
FOA14	RADIAL	88	43	91V
FOA15	RADIAL	152	85	155V
FOA16	RADIAL	166	95	169W
FOA17	RADIAL	223	133	226V
FOA18	RADIAL	287	175	290V

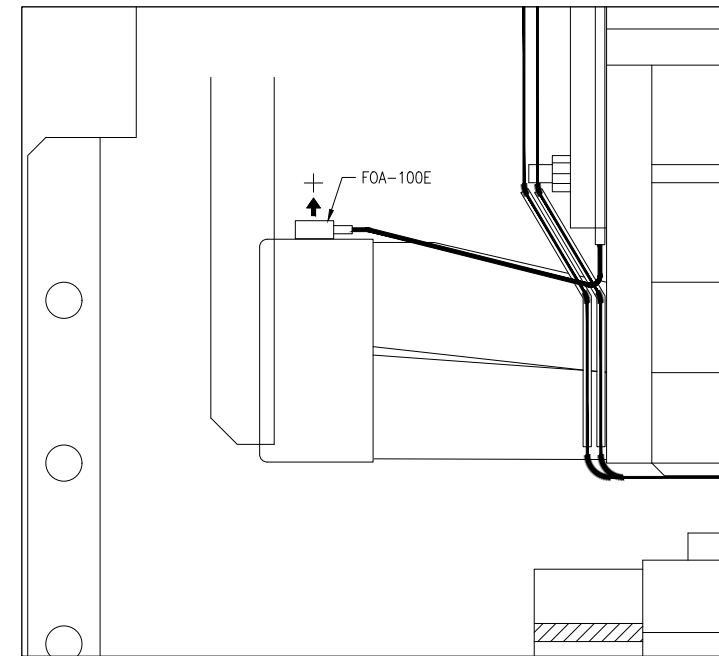
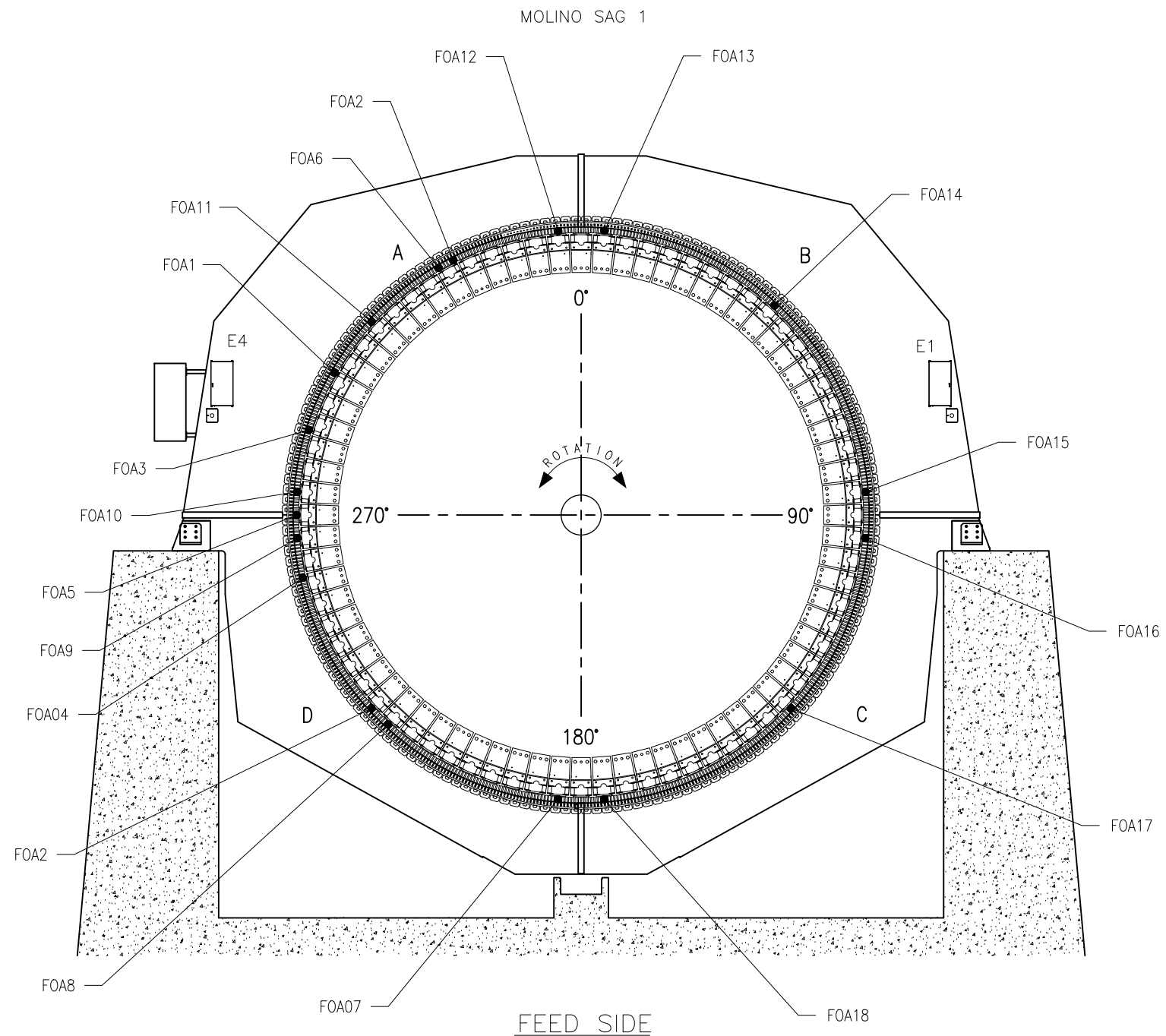

FOA-100E TYPICAL LOCATION

↑ : PROBE'S SIGNAL INCREASES WHEN MOVING IN THAT DIRECTION

A

A

B

B

C

C

D

D

CADREBH2023revB



© Copyright VibroSystM inc.2023
 VibroSystM inc. reserves the right to make changes without prior notice to improve the product.

Section: B MEASURING CHAINS LOCATIONS & INSTALLATION DETAILS

Product number: VSM-CAB-MINE1-100

Drawing number: VSM-DWG-MINE1-100

Sheet: B3 Rev.: 1

Title: ZOOM MONITORING SYSTEM FOR PROJECT: YOUR MINING SITE
 END-WINDING (FOA) SENSOR DETAILS

1

2

3

4

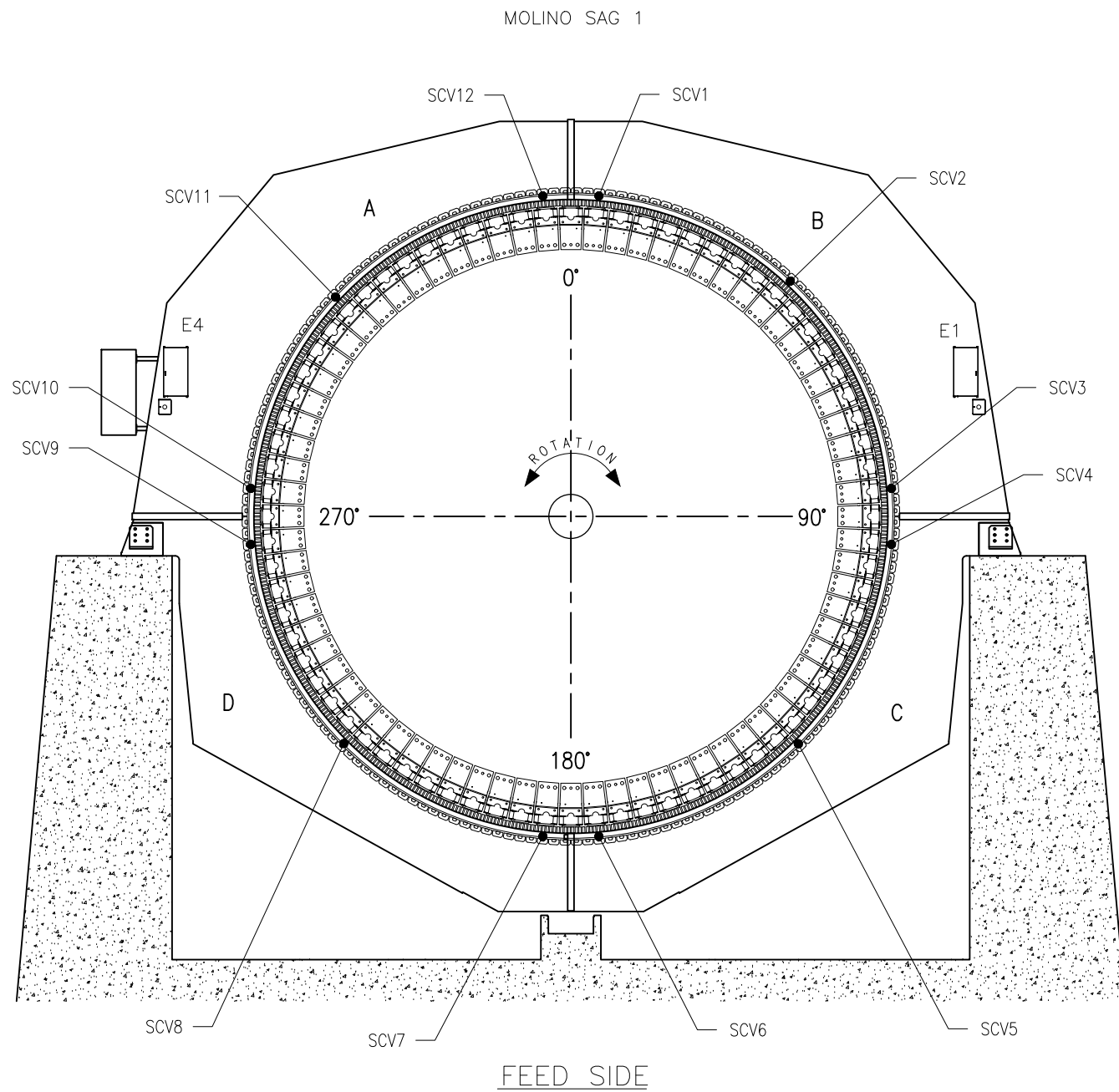

SENSOR DETAILS			
VSM TAG	MESURING AXIS	ANGLE	BETWEEN KEY BARS #
SCV1	RADIAL	4	2 3
SCV2	RADIAL	46	23 24
SCV3	RADIAL	86	43 44
SCV4	RADIAL	94	47 48
SCV5	RADIAL	136	68 69
SCV6	RADIAL	176	88 89

SCV7	RADIAL	184	92 93
SCV8	RADIAL	226	113 114
SCV9	RADIAL	266	133 134
SCV10	RADIAL	274	137 138
SCV11	RADIAL	316	158 159
SCV12	RADIAL	356	178 179

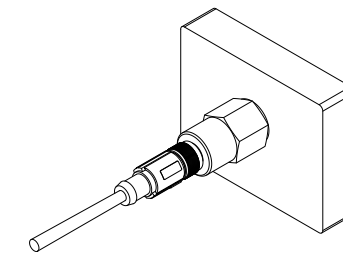

VSM797S WITH ISOLATING PLATE

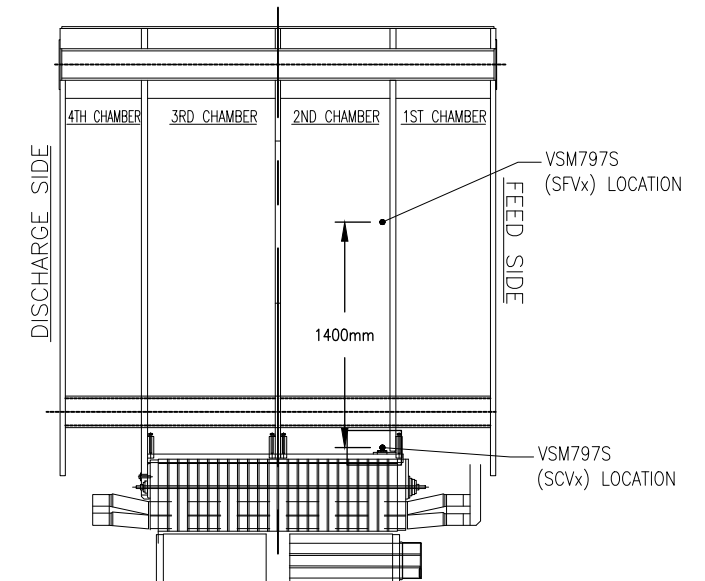

A

A

B

B

C

C

D

D

CADREB2023revB



© Copyright VibroSystM inc.2023
 VibroSystM inc. reserves the right to make changes without prior notice to improve the product.

Section: B MEASURING CHAINS LOCATIONS & INSTALLATION DETAILS
 Product number: VSM-CAB-MINE1-100
 Drawing number: VSM-DWG-MINE1-100
 Sheet: B4 Rev. : 1

Title: ZOOM MONITORING SYSTEM FOR PROJECT: YOUR MINING SITE
 STATOR CORE SENSORS DETAILS

1

2

3

4

VSM-DWG-MINE1-100-B4-1.DWG

1

2

3

4

SENSOR DETAILS				
VSM TAG	MESURING AXIS	ANGLE	BETWEEN KEY BARS #	
SFV1	RADIAL	46	23	24
SFV2	RADIAL	136	68	69
SFV3	RADIAL	226	113	114
SFV4	RADIAL	316	158	159

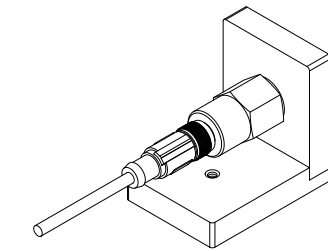
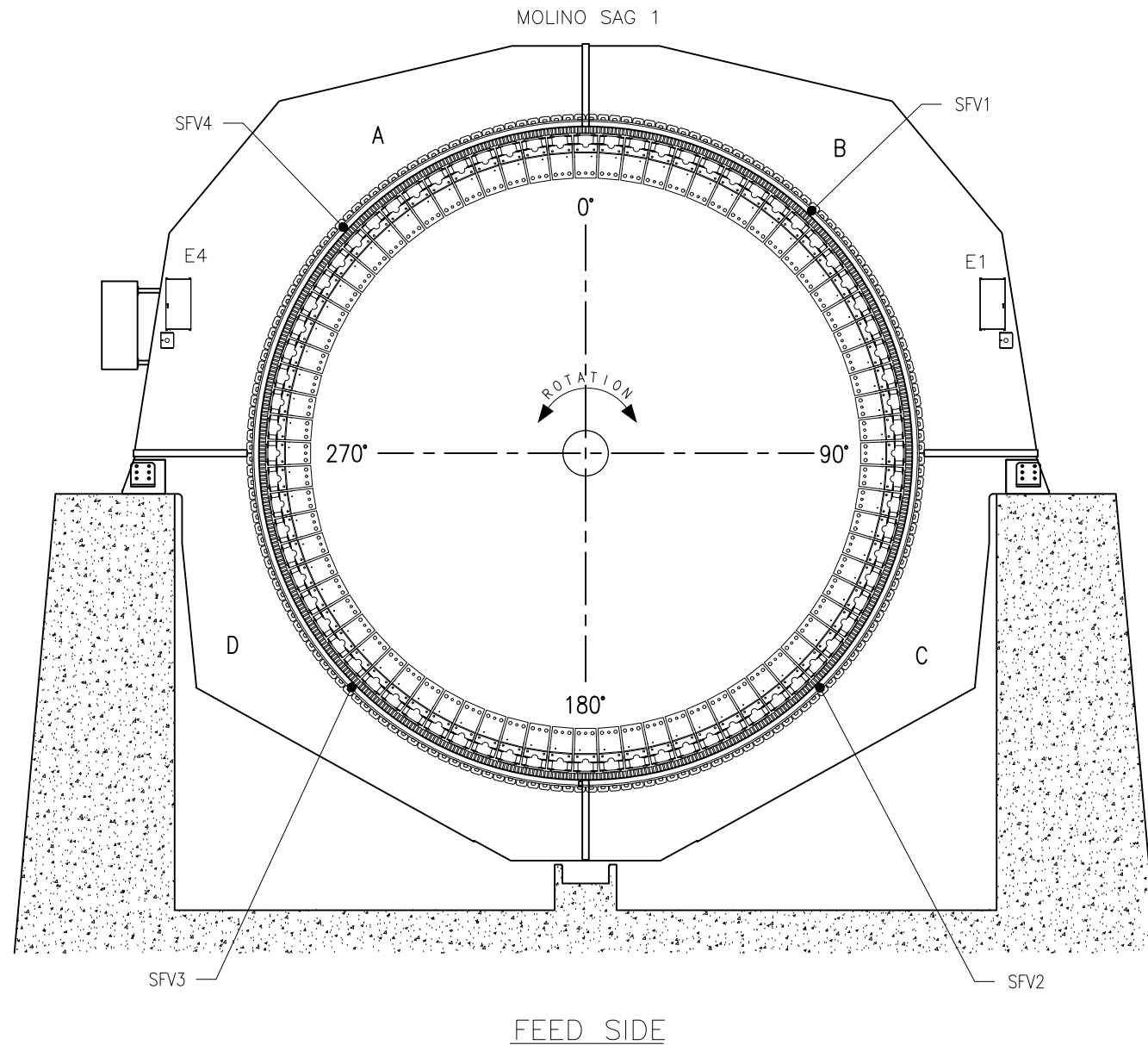

VSM797S WITH 90° ISOLATING PLATE

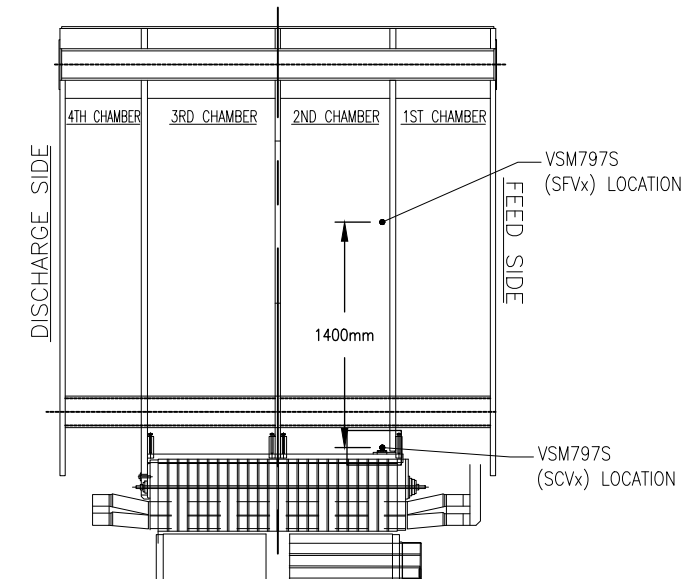

A

A

B

B

C

C

D

D

CADREBH2023revB



© Copyright VibroSystM inc.2023
 VibroSystM inc. reserves the right to make changes without prior notice to improve the product.

Section: B MEASURING CHAINS LOCATIONS & INSTALLATION DETAILS
 Product number: VSM-CAB-MINE1-100
 Drawing number: VSM-DWG-MINE1-100
 Sheet: B5 Rev.: 1

Title: ZOOM MONITORING SYSTEM FOR PROJECT: YOUR MINING SITE
 STATOR FRAME SENSORS DETAILS

1

2

3

4

1

2

3

4

A

A

B

B

C

C

D

D

SENSOR DETAILS		
VSM TAG	MESURING AXIS	TYPICAL LOCATION
SPV1	VERTICAL	90°
SPV2	VERTICAL	270°

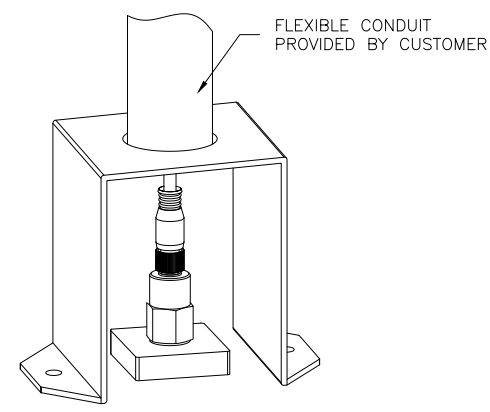
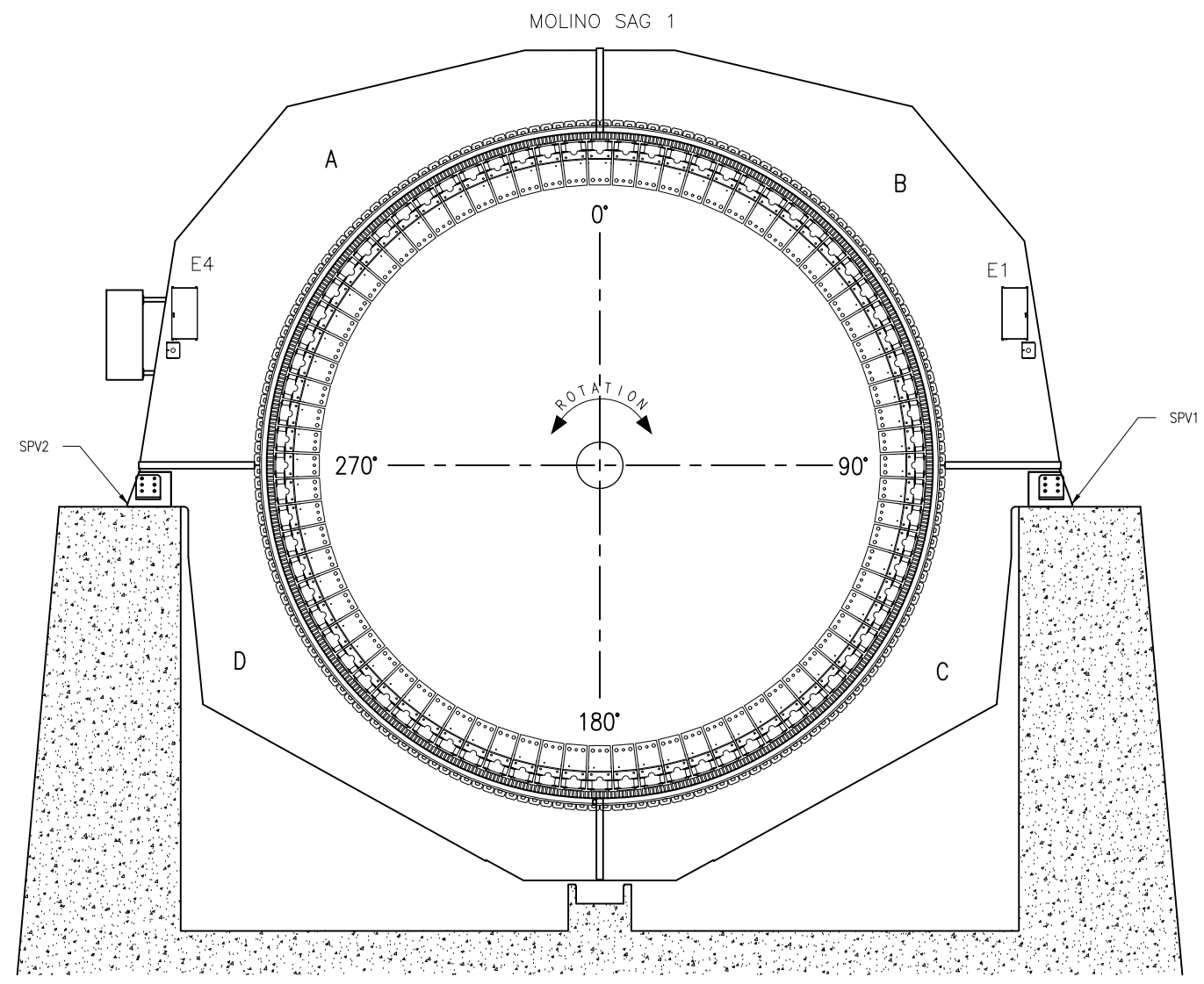

VSM797S WITH ISOLATING PLATE & PROTECTION COVER

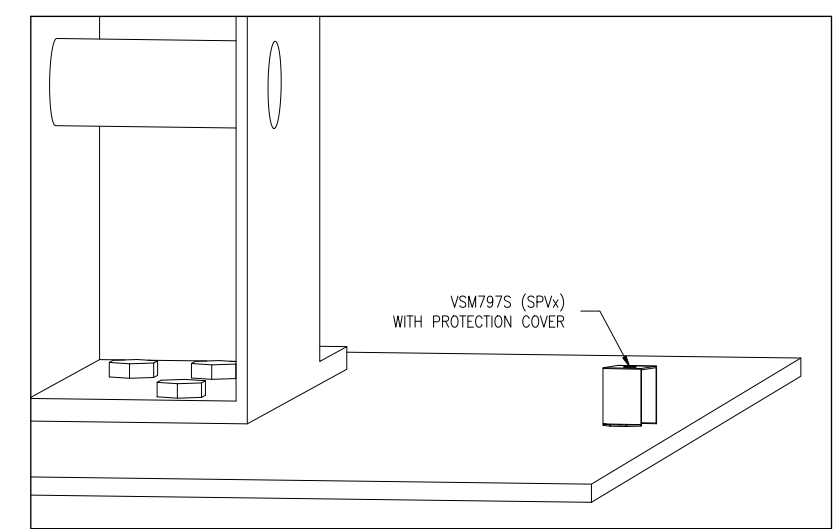

VSM797S (SPVx) LOCATION

THE LOCATION MUST NOT INTERFERE WHEN CHANGING THE STATOR IN MAINTENANCE POSITION

CADREBH2023revB



© Copyright VibroSystM inc.2023
 VibroSystM inc. reserves the right to make changes without prior notice to improve the product.

Section: B		MEASURING CHAINS LOCATIONS & INSTALLATION DETAILS		Title: ZOOM MONITORING SYSTEM FOR PROJECT: YOUR MINING SITE	
Product number:	VSM-CAB-MINE1-100	Drawing number:	VSM-DWG-MINE1-100	Sheet:	Rev. :
				B6	1

SOLE PLATE SENSORS DETAILS

1

2

3

4

1

2

3

4

A

A

B

B

C

C

D

D

SENSOR DETAILS			
COMM INTERFACE #	FROM	TO	INSTALL IN THE MIDDLE OF 2 KEYBAR
HAVSM1	SCT1*	SCT45	FEED SIDE QUADRANT B
HAVSM2	SCT46	SCT90	FEED SIDE QUADRANT C
HAVSM3	SCT91	SCT135	FEED SIDE QUADRANT D
HAVSM4	SCT136	SCT180	FEED SIDE QUADRANT A

* IT'S IMPORTANT TO FIRST DETERMINE THE POSITIONING OF SCT1 BECAUSE THIS WILL AFFECT THE POSITIONING OF THE OTHER SENSORS IN THE CHAIN

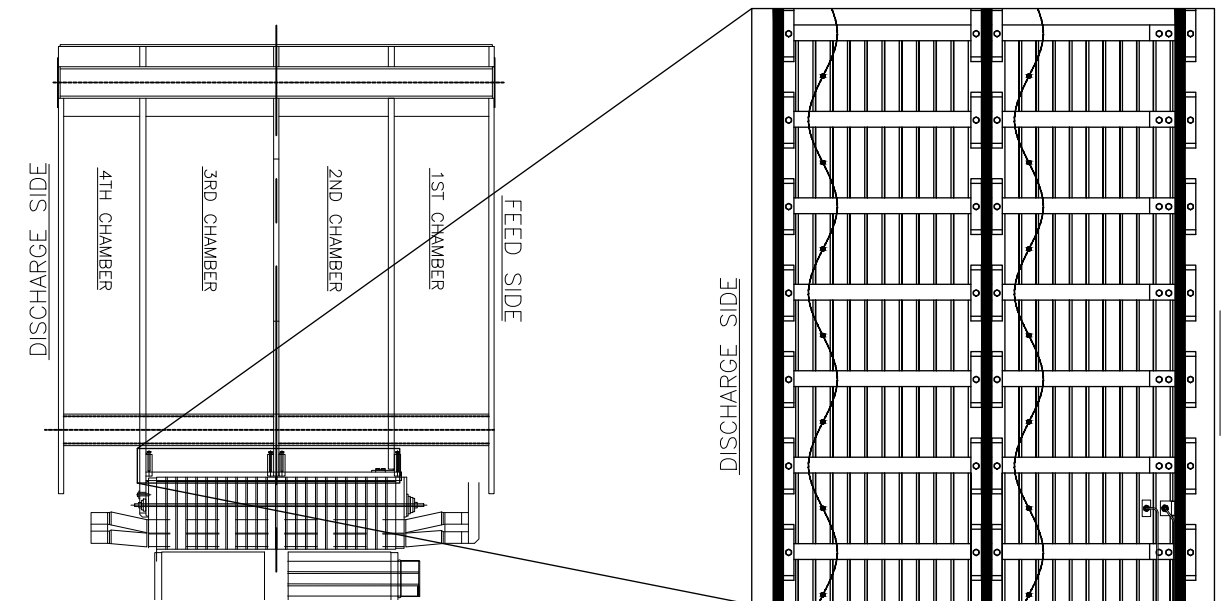
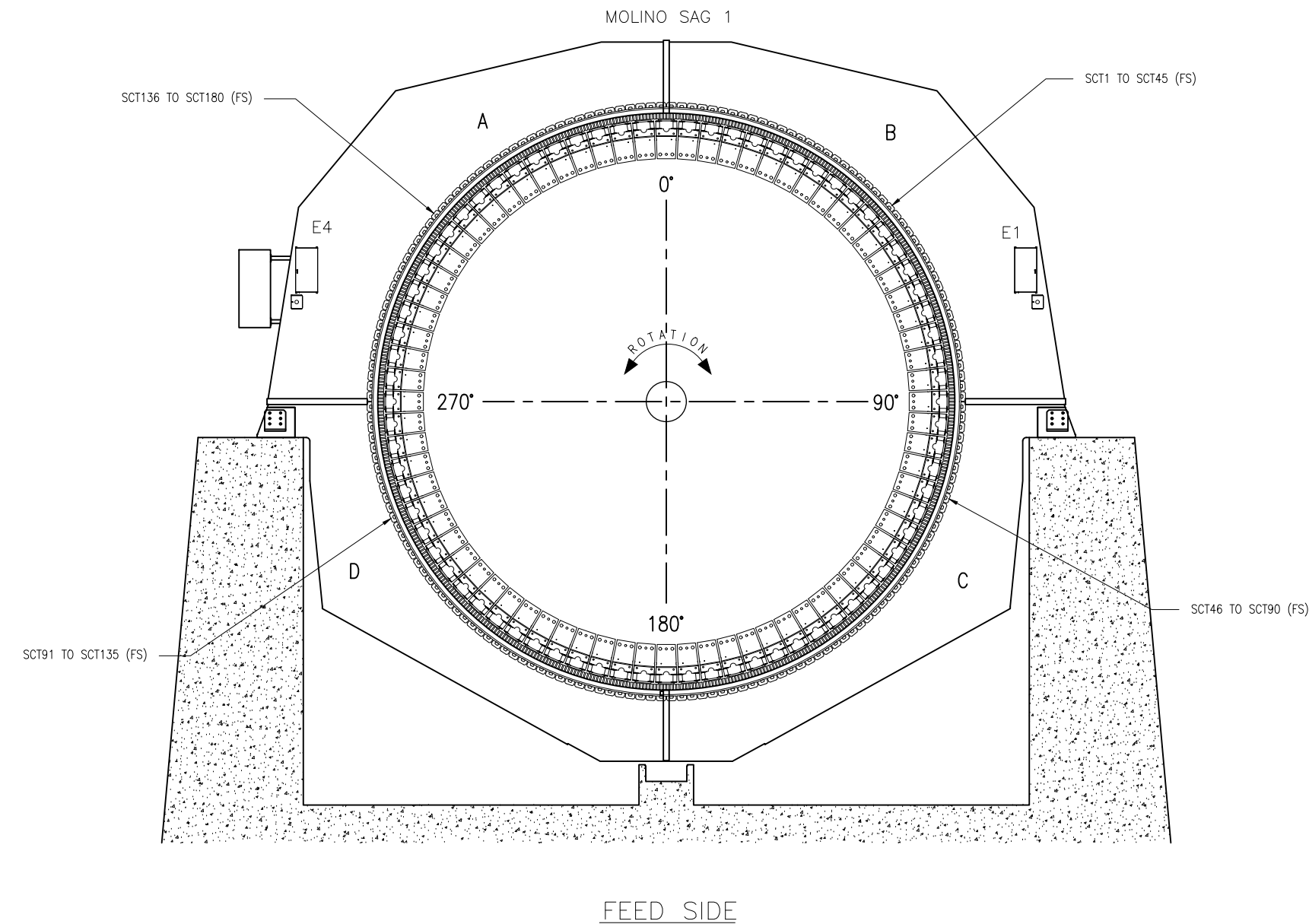

CADREB2023revB



© Copyright VibroSystM inc.2023
 VibroSystM inc. reserves the right to make changes without prior notice to improve the product.

Section: B MEASURING CHAINS LOCATIONS & INSTALLATION DETAILS
 Product number: VSM-CAB-MINE1-100
 Drawing number: VSM-DWG-MINE1-100
 Sheet: B7 Rev.: 1

Title: ZOOM MONITORING SYSTEM FOR PROJECT: YOUR MINING SITE
 THERMAWATCH STATOR DETAILS FEED SIDE

1

2

3

4

VSM-DWG-MINE1-100-B7-1.DWG

1

2

3

4

A

A

B

B

C

C

D

D

SENSOR DETAILS			
COMM INTERFACE #	FROM	TO	INSTALL IN THE MIDDLE OF 2 KEYBAR
HAVSM5	SCT181	SCT225	DISCHARGE SIDE QUADRANT B
HAVSM6	SCT226	SCT270	DISCHARGE SIDE QUADRANT C
HAVSM7	SCT271	SCT315	DISCHARGE SIDE QUADRANT D
HAVSM8	SCT316	SCT360	DISCHARGE SIDE QUADRANT A

* IT'S IMPORTANT TO FIRST DETERMINE THE POSITIONING OF SCT181 BECAUSE THIS WILL AFFECT THE POSITIONING OF THE OTHER SENSORS IN THE CHAIN

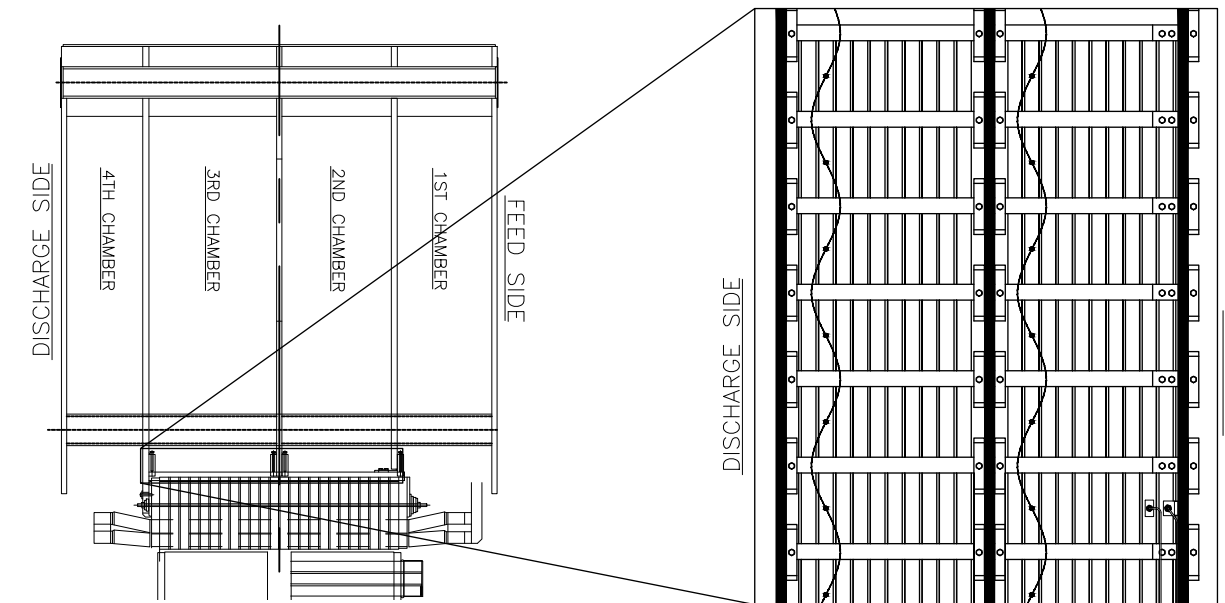
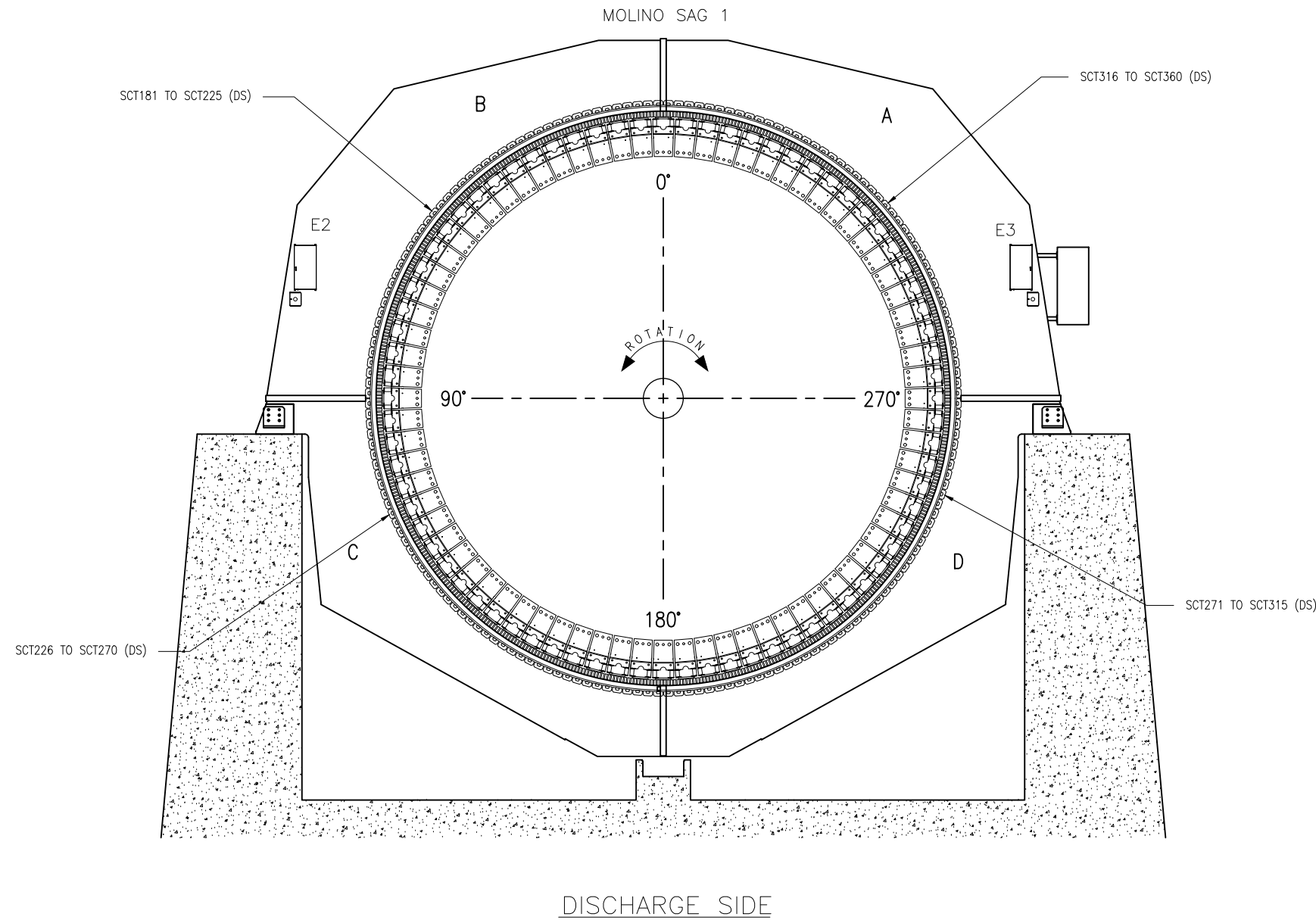

CADREB2023revB



© Copyright VibroSystM inc.2023
 VibroSystM inc. reserves the right to make changes without prior notice to improve the product.

Section: B MEASURING CHAINS LOCATIONS & INSTALLATION DETAILS
 Product number: VSM-CAB-MINE1-100
 Drawing number: VSM-DWG-MINE1-100
 Sheet: B8 Rev. : 1

Title: ZOOM MONITORING SYSTEM FOR PROJECT: YOUR MINING SITE
 THERMAWATCH STATOR DETAILS DISCHARGE SIDE

1

2

3

4

1

2

3

4

SENSOR DETAILS		
SENSOR #	MESURING AXIS	TYPICAL LOCATION
SYN1	AXIAL	90° FS
SYN2	AXIAL	90° FS

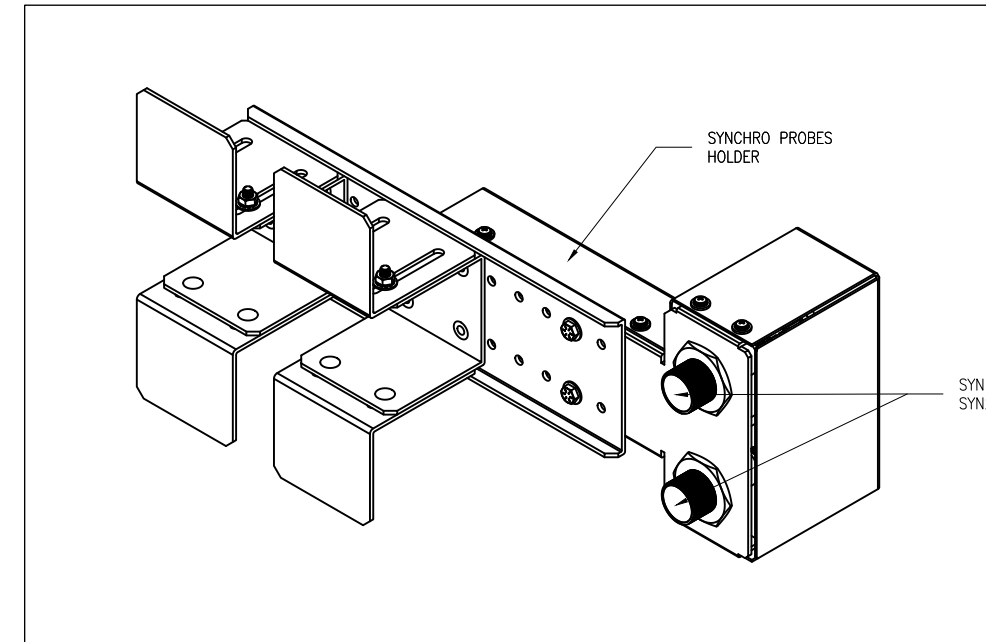
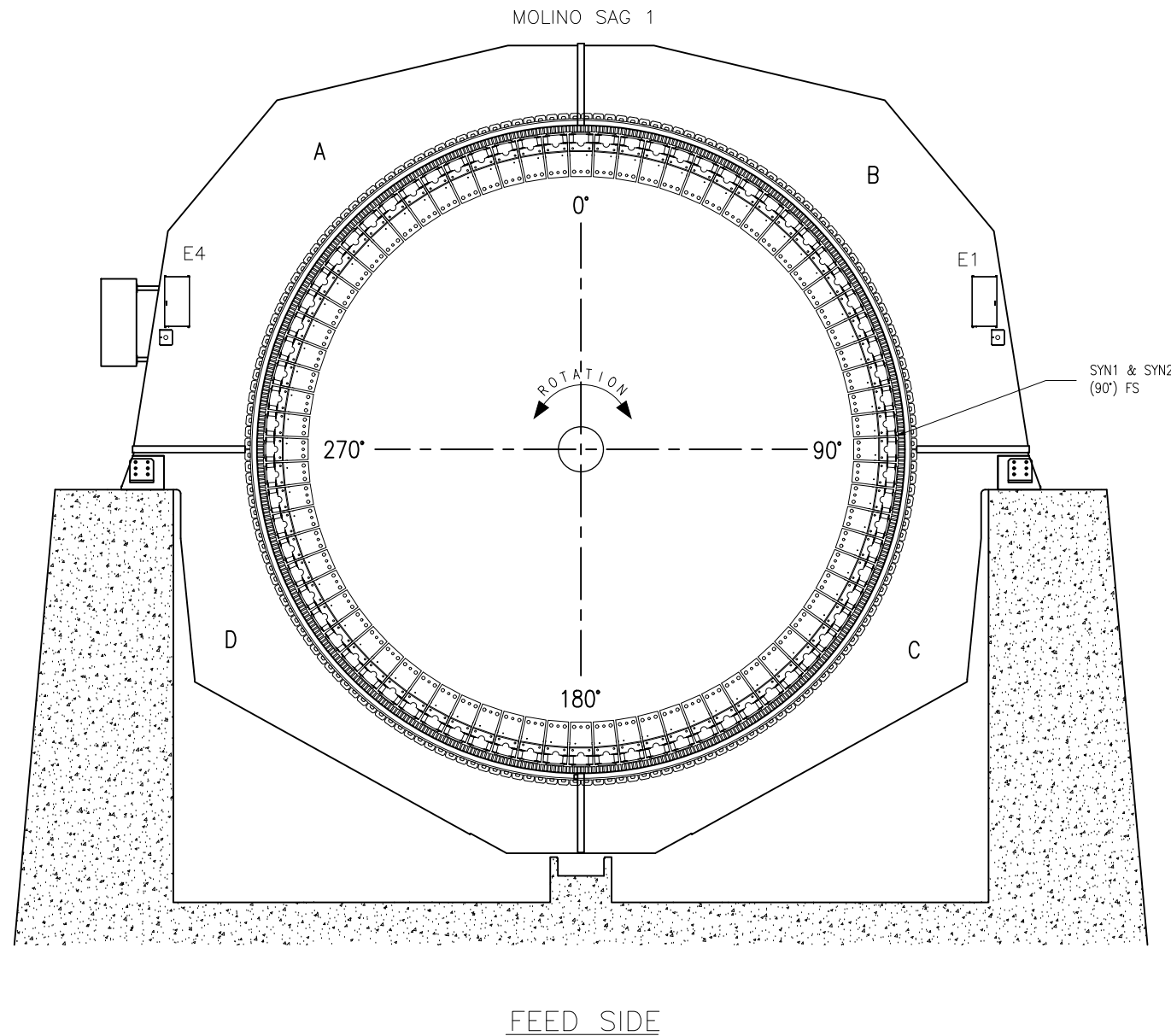

SYNCHRO PROBES

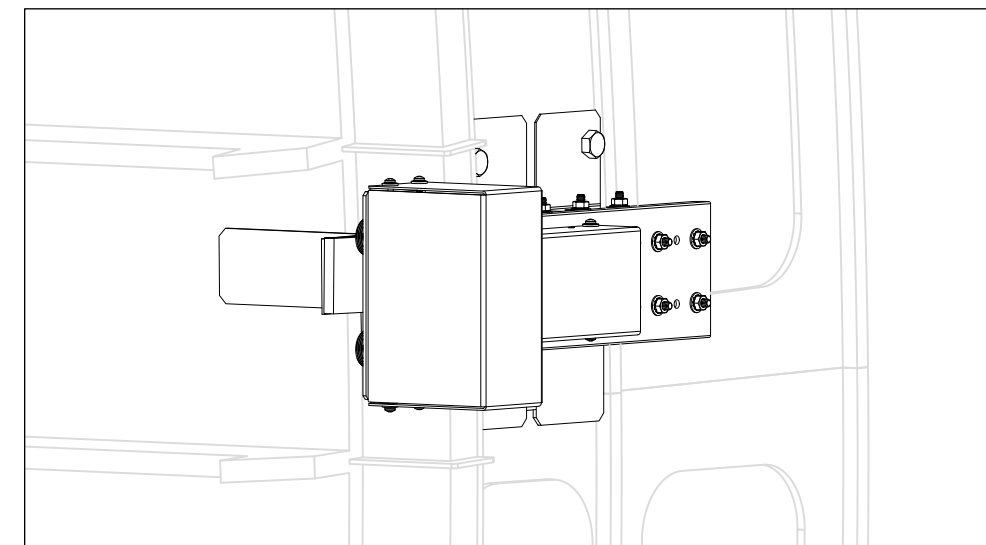

TYPICAL INSTALLATION SYNCHRO PROBES

CADREB2023revB



© Copyright VibroSystM inc.2023
 VibroSystM inc. reserves the right to make changes without prior notice to improve the product.

Section: B MEASURING CHAINS LOCATIONS & INSTALLATION DETAILS
 Product number: VSM-CAB-MINE1-100
 Drawing number: VSM-DWG-MINE1-100
 Sheet: B9 Rev. : 1

Title: ZOOM MONITORING SYSTEM FOR PROJECT: YOUR MINING SITE
 SYNCHRONIZATION PROBES DETAILS

1

2

3

4

1

2

3

4

A

A

B

B

C

C

D

D

SENSOR DETAILS		
SENSOR #	MESURING AXIS	TYPICAL LOCATION
TWR1	AXIAL	45° FS
TWR2	AXIAL	45° DS

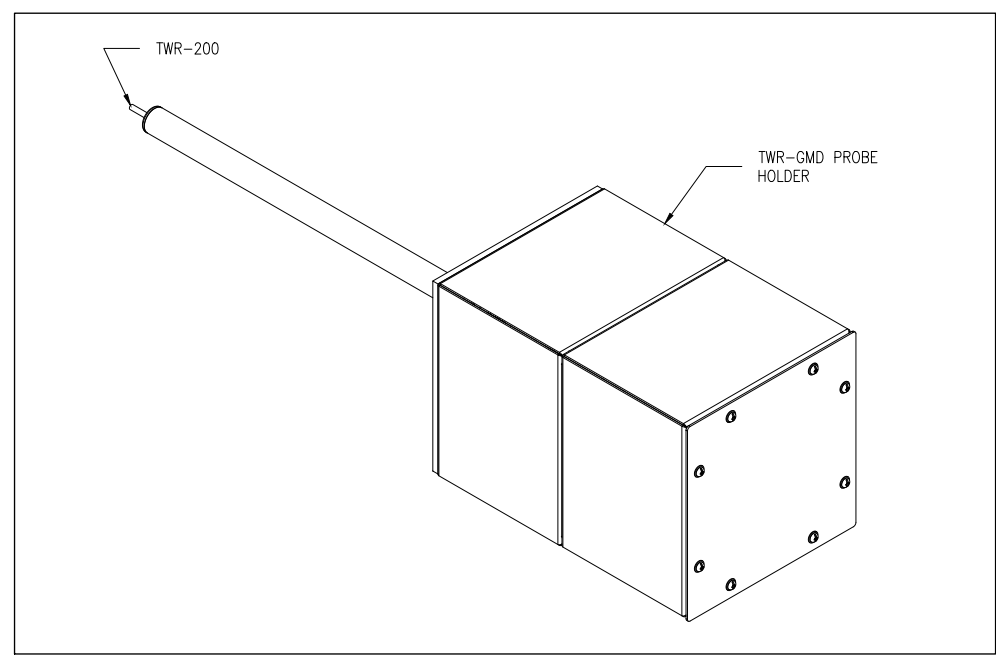
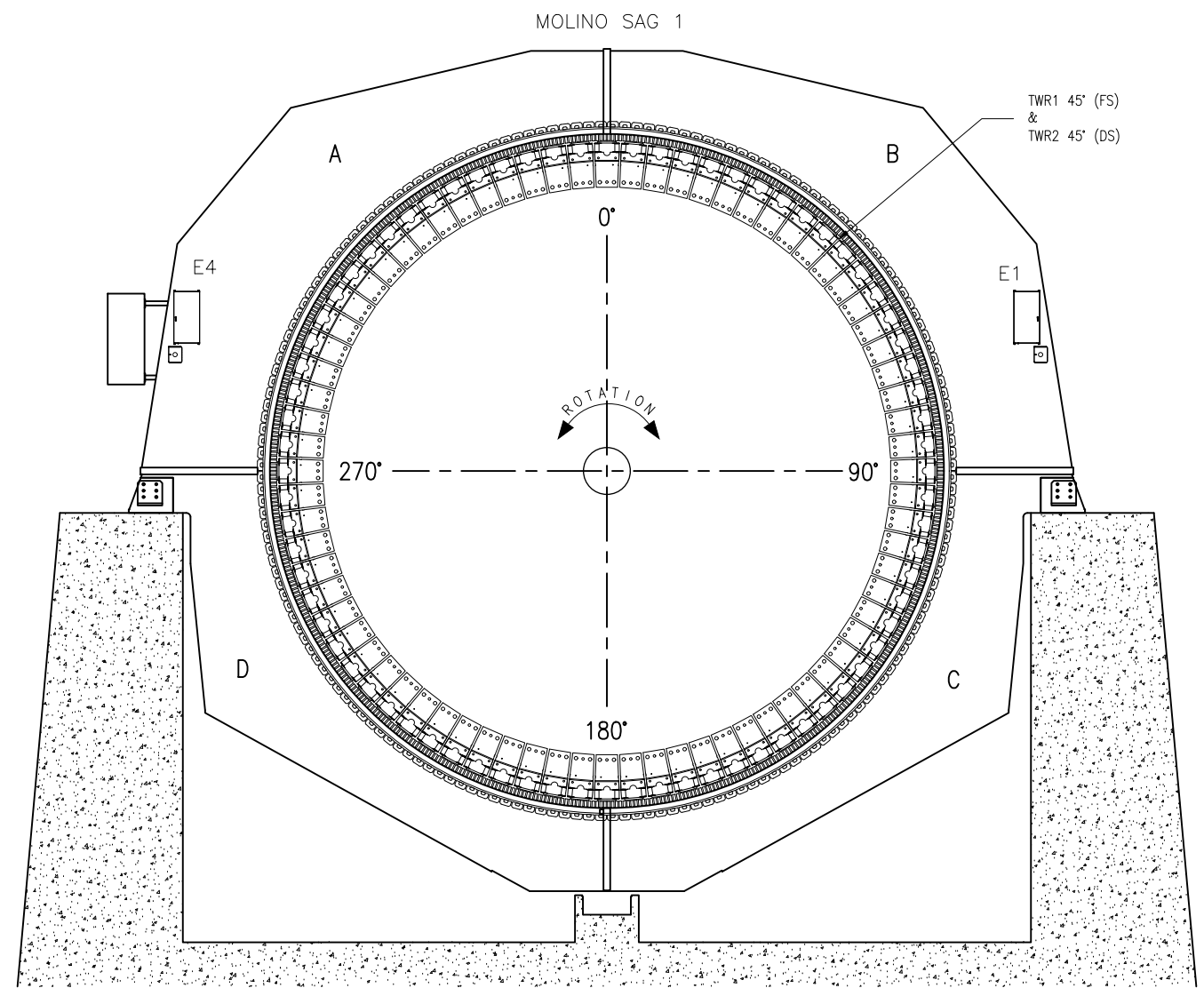

AXIAL TWR-200

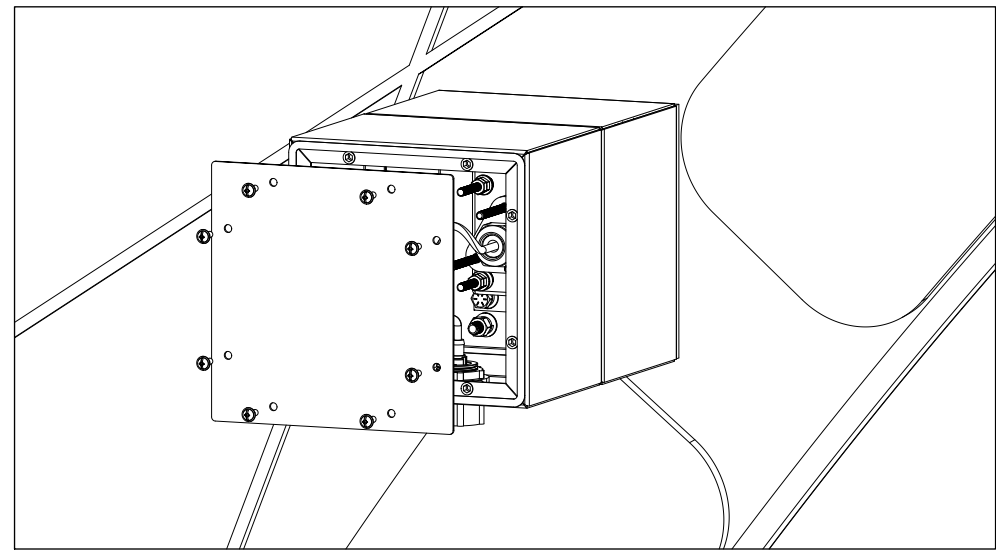

TWR-GMD PROBE HOLDER FOR TWR-200

CADREB2023revB



© Copyright VibroSystM inc. 2023
 VibroSystM inc. reserves the right to make changes without prior notice to improve the product.

Section: B	MEASURING CHAINS LOCATIONS & INSTALLATION DETAILS		Title: ZOOM MONITORING SYSTEM FOR PROJECT: YOUR MINING SITE	
Product number: VSM-CAB-MINE1-100	Drawing number: VSM-DWG-MINE1-100	Sheet: B10	Rev.: 1	THERMAWATCH ROTOR AXIAL DETAILS

1

2

3

4

1

2

3

4

A

B

C

D

A

B

C

D

STRUCTURE AND REAR DOOR: STEEL (2 mm/ 78.7 mils)
 SIDE PANELS: STEEL (1,5 mm/ 60 mils)
 PAINT THICKNESS: 100 µm/ 80 µm MINIMUM
 PAINT COATING: 3 STAGE: NANOCERAMIC COATING, ELECTROPHORETIC DIPCOAT-PRIMER, TEXTURED POWDER-COATING
 PROTECTION: IP54, NEMA 12

FRONT DOOR: ALUMINIUM, SINGLE-PANE SAFETY GLASS 3 mm,
 WITH KEY HANDLE
 REAR DOOR: SOLID, KEY HANDLE

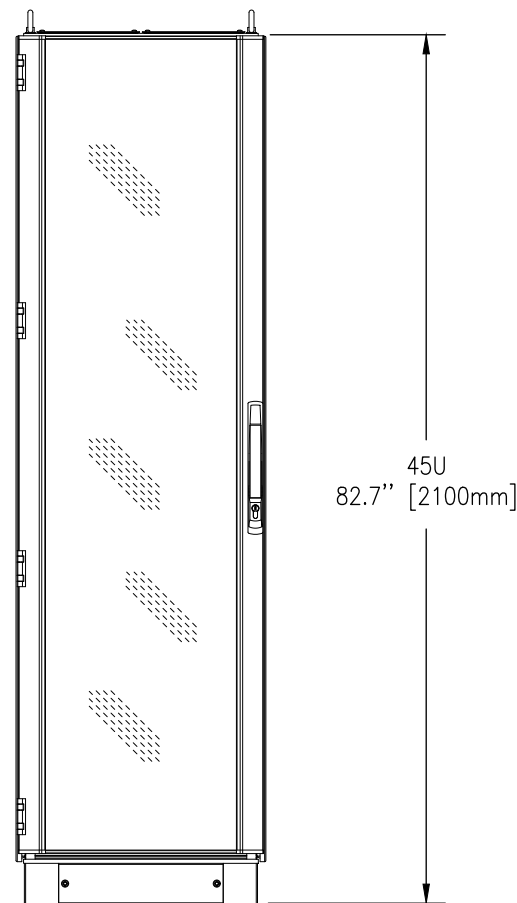
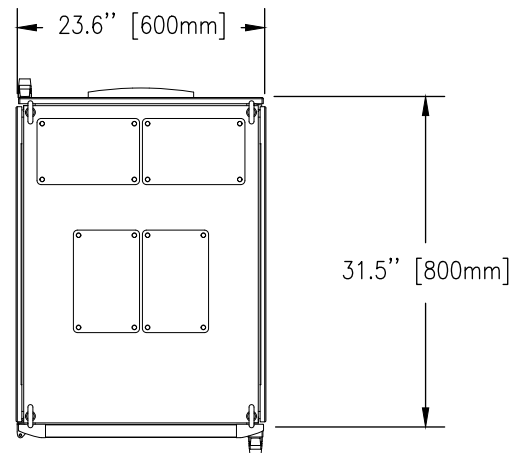

FRONT VIEW

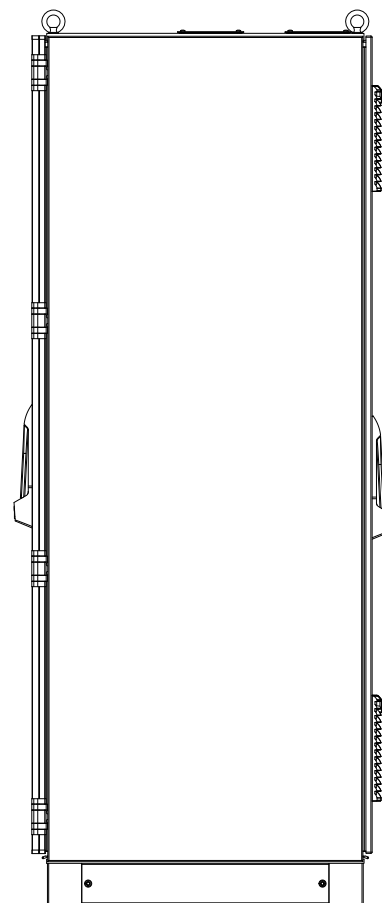

SIDE VIEW

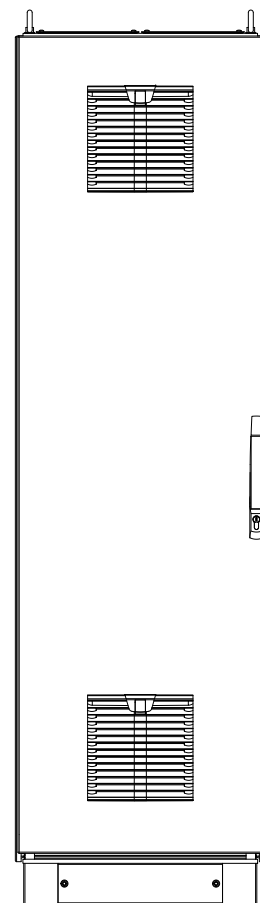

REAR VIEW

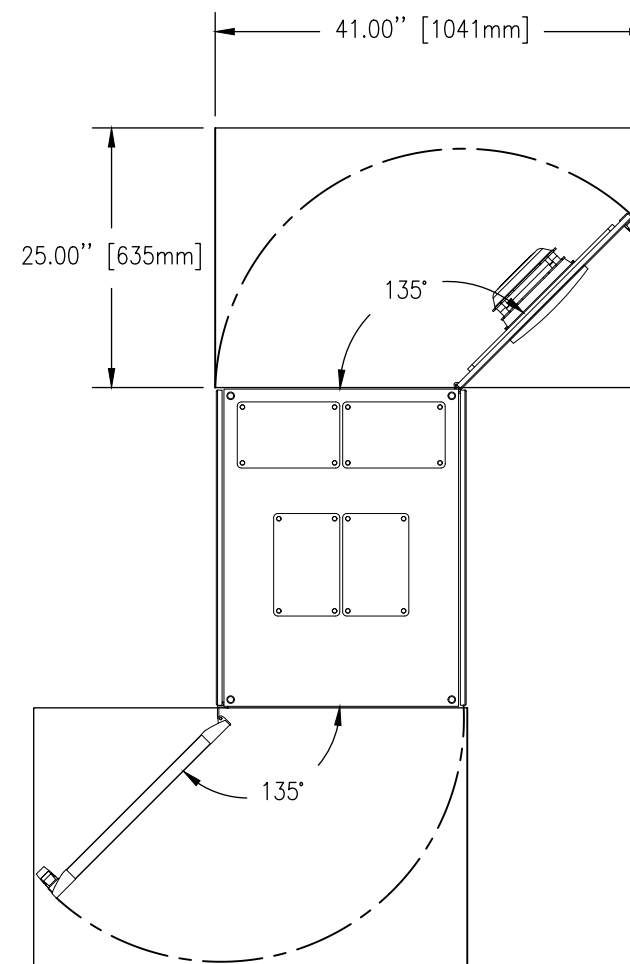

AREA REQUIRED FOR PROPER ACCESS TO COMPONENTS AND CONNECTIONS

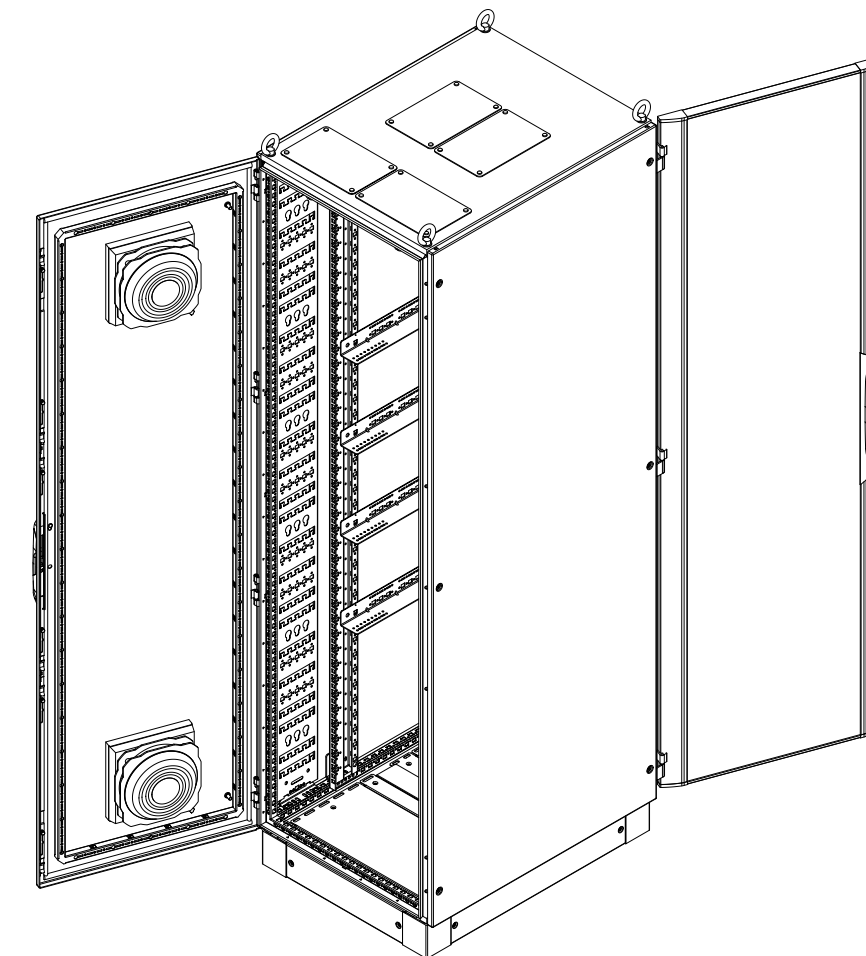

CABINET LOCATION:
 THE MONITORING CABINET MUST BE INSTALLED IN E-HOUSE

CADREH2023revB



© Copyright VibroSystM inc.2023
 VibroSystM inc. reserves the right to make changes without prior notice to improve the product.

Section: C		MECHANICAL	
Product number: VSM-CAB-MINE1-100	Drawing number: VSM-DWG-MINE1-100	Sheet: C1	Rev. : 1

Title: ZOOM MONITORING SYSTEM FOR PROJECT: YOUR MINING SITE
 MONITORING CABINET EXTERIOR LAYOUT

1

2

3

4

1

2

3

4

A

A

B

B

C

C

D

D

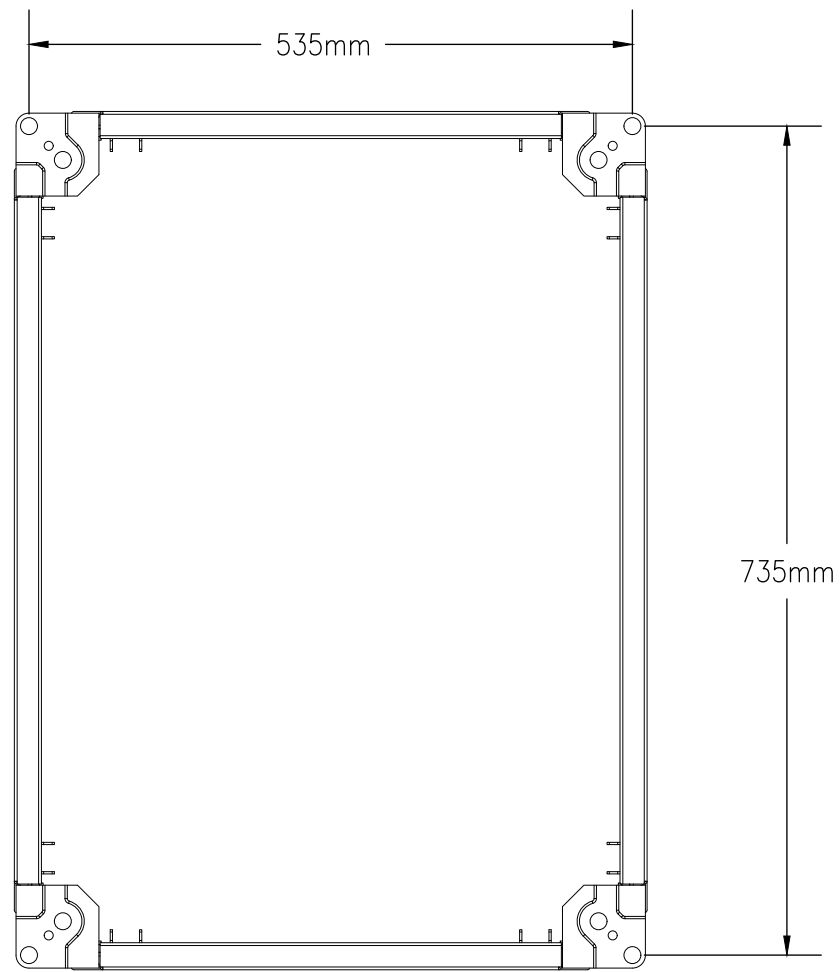
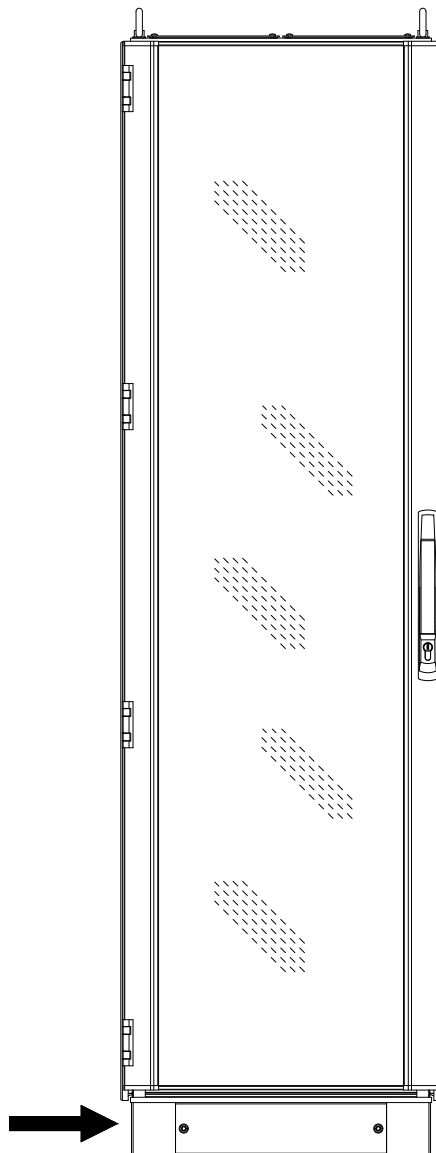
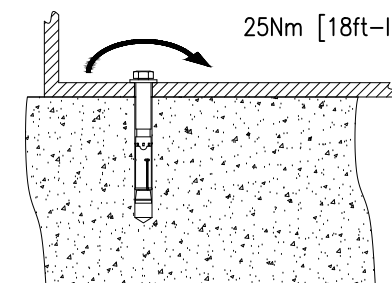
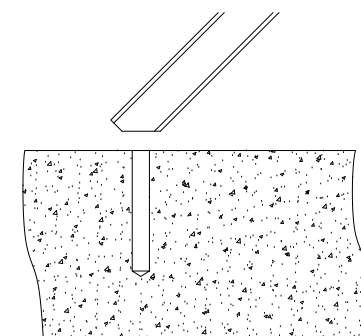
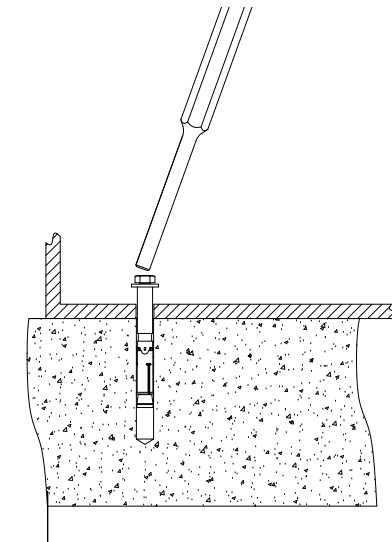
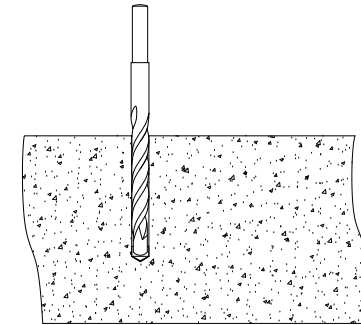
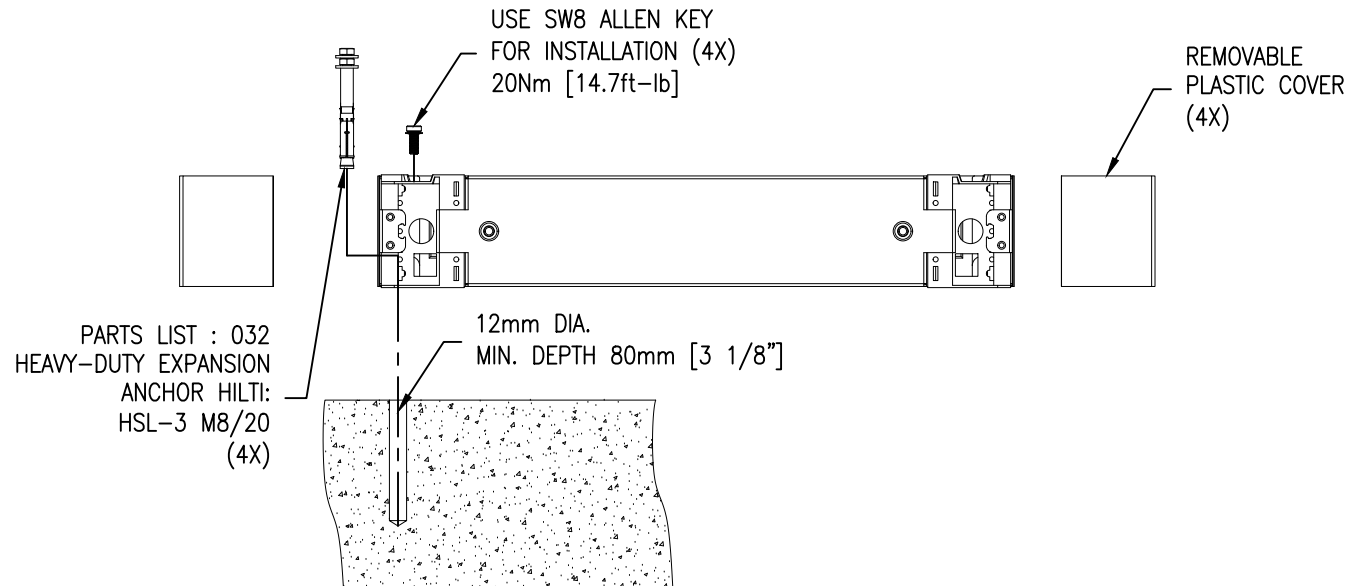

CADREH/2023/revB



© Copyright VibroSystM inc.2023		Section: C		MECHANICAL	
VibroSystM inc. reserves the right to make changes without prior notice to improve the product.		Product number: VSM-CAB-MINE1-100	Drawing number: VSM-DWG-MINE1-100	Sheet: C2	Rev. : 1

Title: ZOOM MONITORING SYSTEM FOR PROJECT: YOUR MINING SITE
MONITORING CABINET ANCHOR INSTALLATION

1

2

3

4

1

2

3

4

THE UNTHREADED HOLE POSITION IS ONLY INDICATIVE AND SHOULD BE CONFIRMED ACCORDING TO OBSTACLES THAT CAN BE FOUND INSIDE AND LIMITING THE PASSAGE OF CABLES.

THE BOX ARRANGEMENTS ARE ONLY INDICATIVE. THEIR POSITIONS CAN BE ADJUSTED.

DO NOT DRILL HOLES TO PASS CABLES THROUGH THE BACK OF THE WME E1 & E4. THIS WILL PUSH HOT AIR FROM THE MILL IN THE WME. PASS THE CABLES THROUGH THE TOP/BOTTOM OR THROUGH THE SIDES OF THE WME

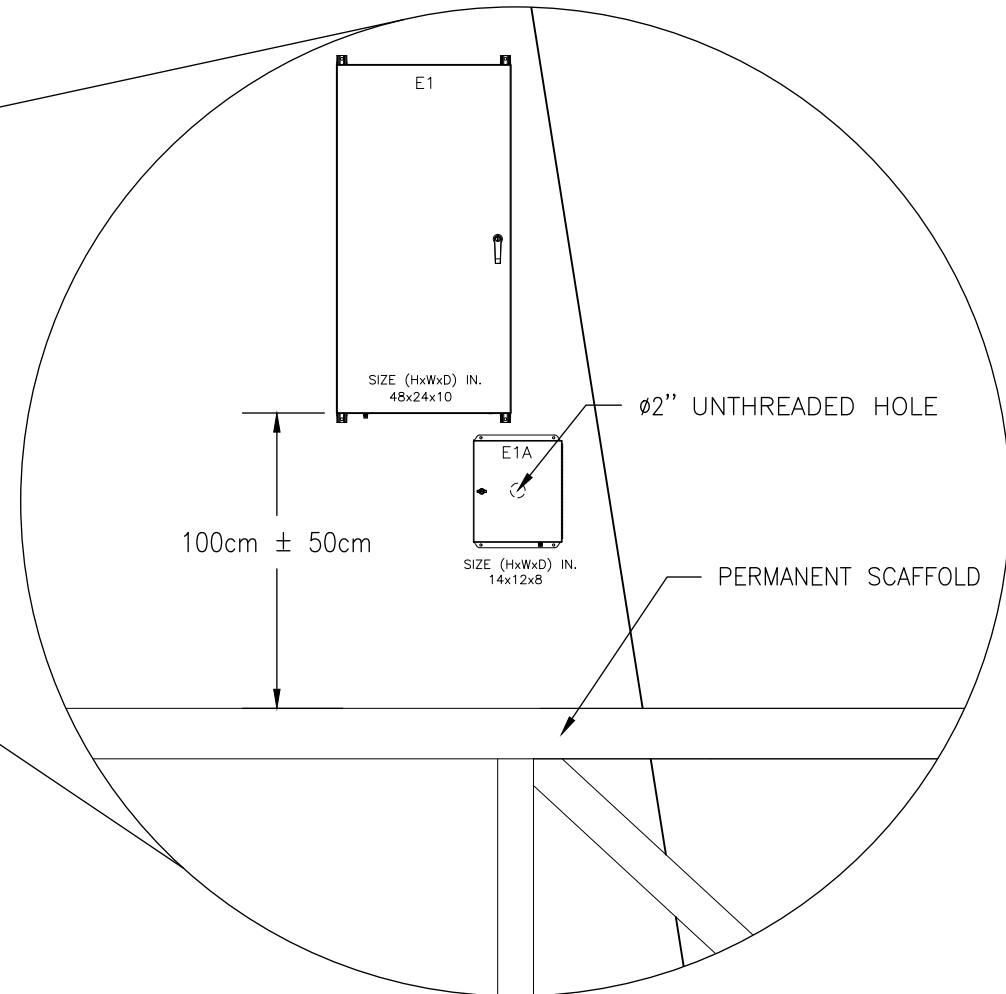
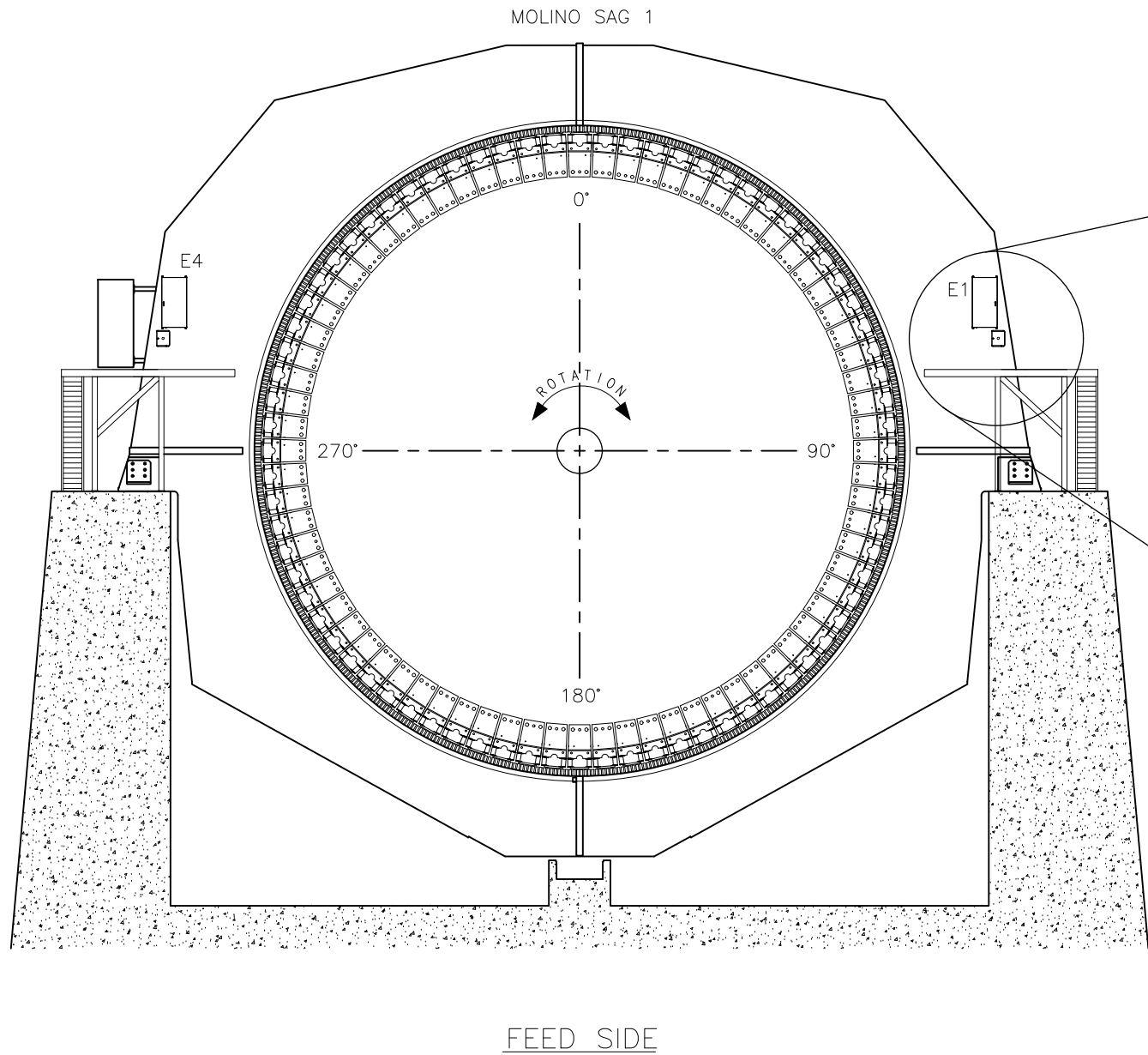

THE PASSTHROUGH BOX E1A & E4A ARE INSTALLED UNDERNEATH THEIR RESPECTIVE WME (E1 & E4)

THE WME E1 & E4 MUST BE ACCESSIBLE FROM THE PERMANENT SCAFFOLDS OF THE MILL. THE BOTTOM OF THE WME MUST BE 100 CM +/- 50 CM FROM THE PERMANENT SCAFFOLDS.

MAKE SURE THAT YOU HAVE THE NECESSARY CLEARANCE TO OPEN THE DOOR OF EACH BOX. SEE SHEET C6 FOR DETAILS

A

A

B

B

C

C

D

D

CADREB/2023revB



© Copyright VibroSystM inc.2023

VibroSystM inc. reserves the right to make changes without prior notice to improve the product.

Section: C

Product number: VSM-CAB-MINE1-100

MECHANICAL

Drawing number: VSM-DWG-MINE1-100

Sheet: C3 Rev.: 1

Title: ZOOM MONITORING SYSTEM FOR PROJECT: YOUR MINING SITE LOCATIONS & CONSIDERATIONS OF WALLMOUNT ENCLOSURES

1

2

3

4

VSM-DWG-MINE1-100-C3-1.DWG

1

2

3

4

THE UNTHREADED HOLE POSITION IS ONLY INDICATIVE AND SHOULD BE CONFIRMED ACCORDING TO OBSTACLES THAT CAN BE FOUND INSIDE AND LIMITING THE PASSAGE OF CABLES.

THE BOX ARRANGEMENTS ARE ONLY INDICATIVE. THEIR POSITIONS CAN BE ADJUSTED.

DO NOT DRILL HOLES TO PASS CABLES THROUGH THE BACK OF THE WME E2 & E3. THIS WILL PUSH HOT AIR FROM THE MILL IN THE WME. PASS THE CABLES THROUGH THE TOP/BOTTOM OR THROUGH THE SIDES OF THE WME

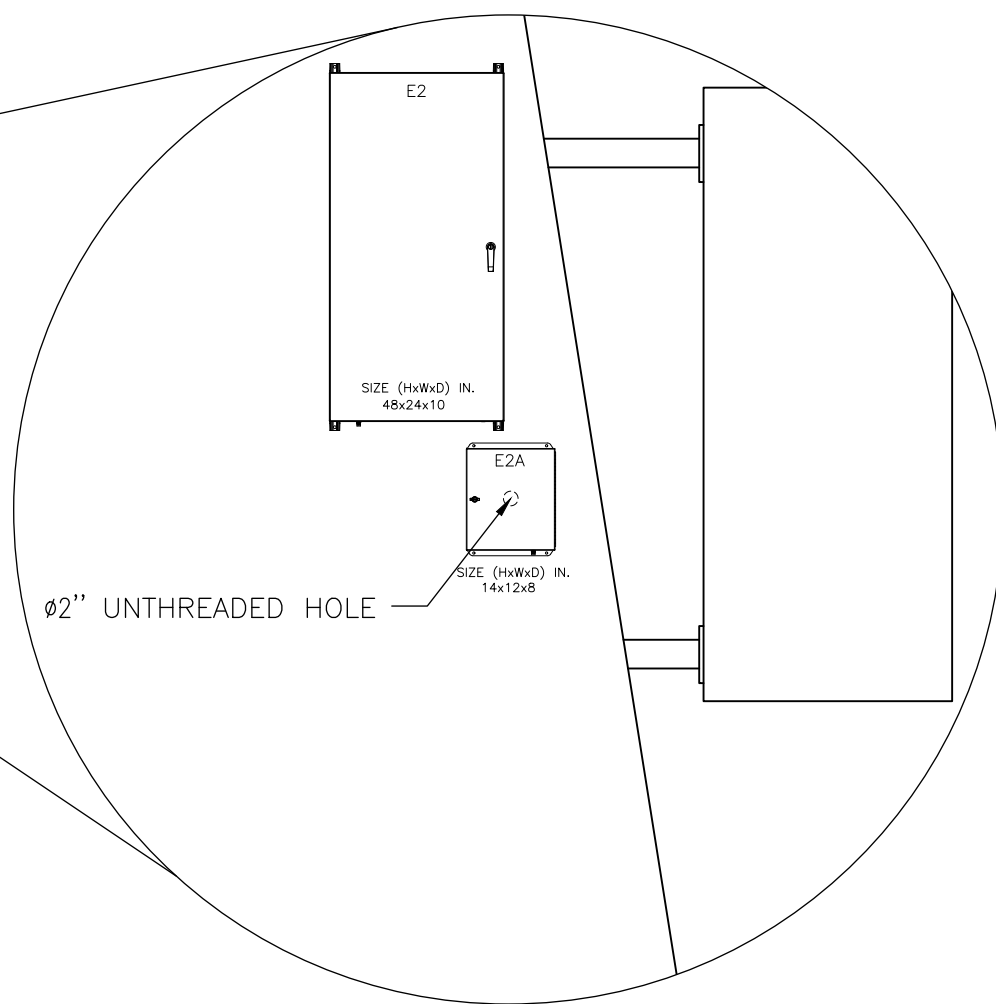
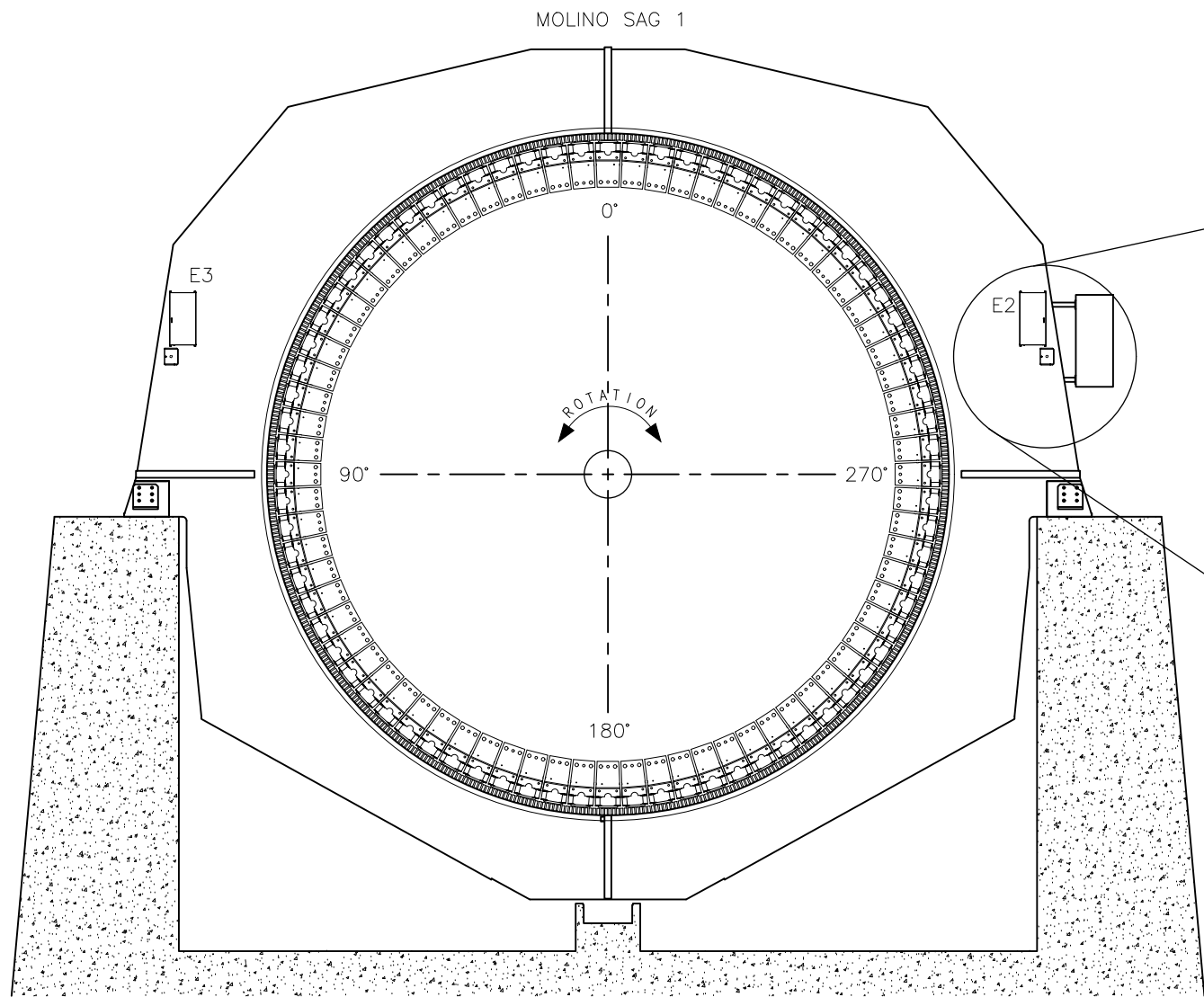

DISCHARGE SIDE

THE PASSTHROUGH BOX E2A & E3A ARE INSTALLED UNDERNEATH THEIR RESPECTIVE WME (E2 & E3)

MAKE SURE THAT YOU HAVE THE NECESSARY CLEARANCE TO OPEN THE DOOR OF EACH BOX. SEE SHEET C6 FOR DETAILS

CADREBH2023revB



© Copyright VibroSystM inc.2023
 VibroSystM inc. reserves the right to make changes without prior notice to improve the product.

Section: C		MECHANICAL		Title: ZOOM MONITORING SYSTEM FOR PROJECT: YOUR MINING SITE LOCATIONS & CONSIDERATIONS OF WALLMOUNT ENCLOSURES	
Product number:	VSM-CAB-MINE1-100	Drawing number:	VSM-DWG-MINE1-100	Sheet:	C4
				Rev. :	1

1

2

3

4

1

2

3

4

A

B

C

D

A

B

C

D

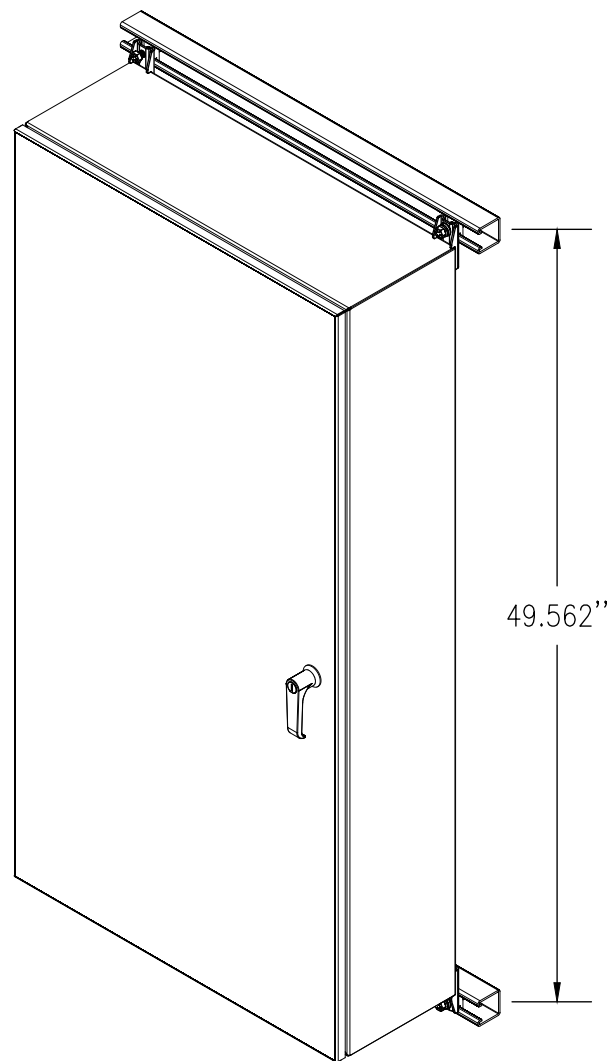

VSM-WME48-F2L2T45 (48X24X8)
(E1)(E4)

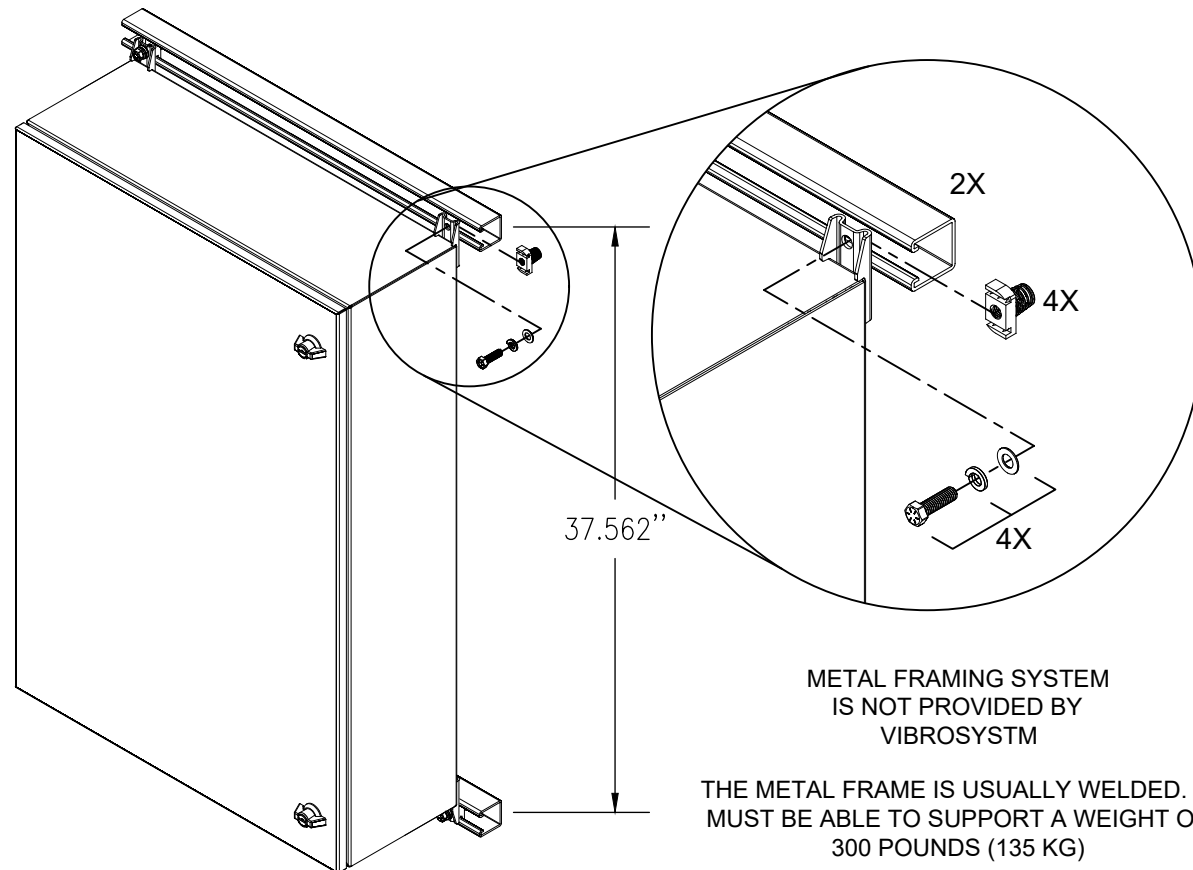

VSM-WME36-L2T18 (36X24X8)
(E2)(E3)

METAL FRAMING SYSTEM
IS NOT PROVIDED BY
VIBROSYSTEM

THE METAL FRAME IS USUALLY WELDED. IT
MUST BE ABLE TO SUPPORT A WEIGHT OF
300 POUNDS (135 KG)

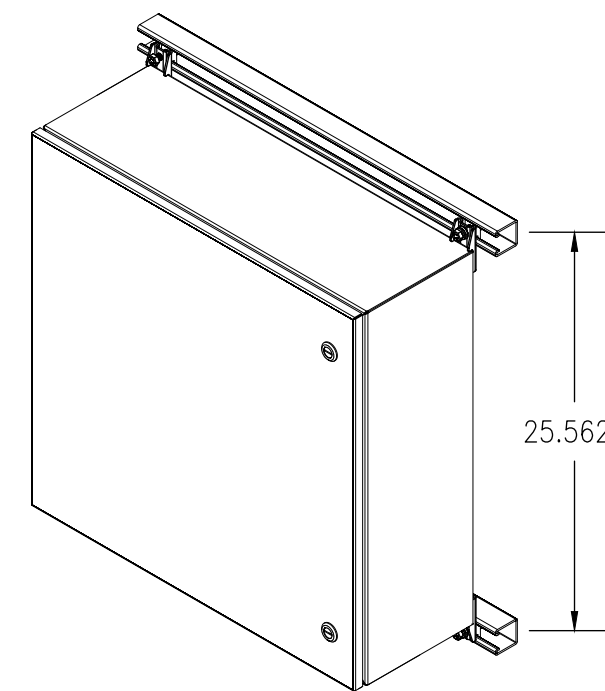

VSM-WME24-T66 (24X24X8)
(E6)(E7)

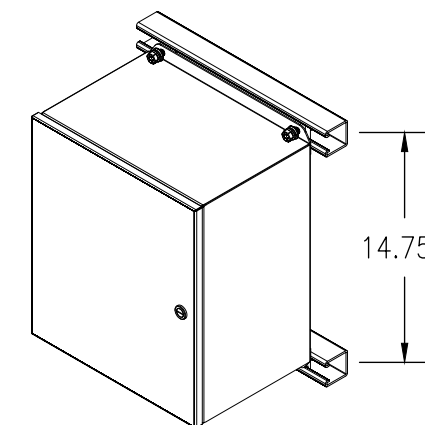

VSM-PBOX-14-12-8 (14X12X8)
(E1A)(E2A)(E3A)(E4A)

CADREH2023revB



© Copyright VibroSystM inc.2023

VibroSystM inc. reserves the right to make changes without prior notice to improve the product.

Section: C

Product number:
VSM-CAB-MINE1-100

MECHANICAL

Drawing number:
VSM-DWG-MINE1-100

Sheet: C5
Rev. : 1

Title: ZOOM MONITORING SYSTEM FOR PROJECT: YOUR MINING SITE
JUNCTION BOXES UNISTRUT DETAILS

1

2

3

4

1

2

3

4

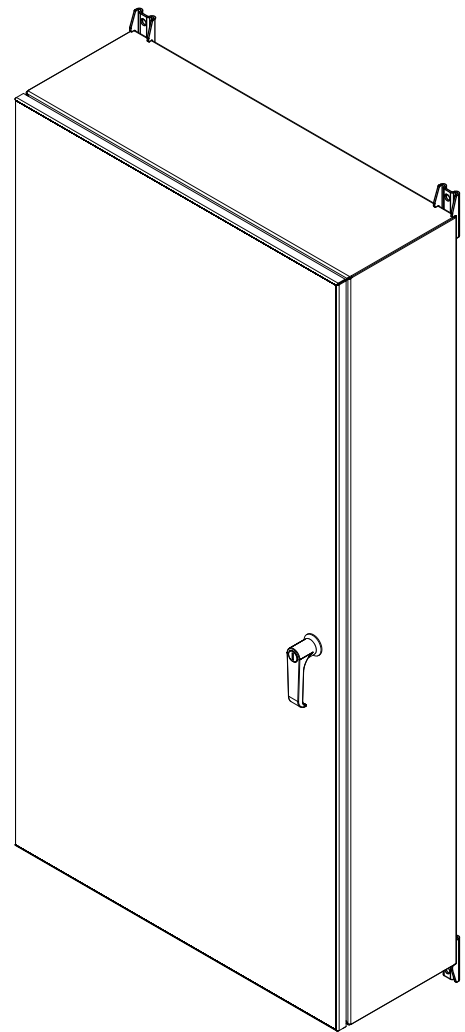

VSM-WME48-F2L2T45 (48X24X8)
(E1)(E4)

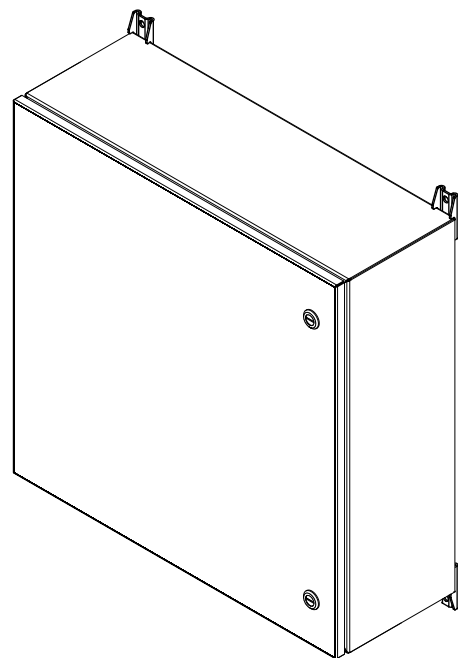

VSM-WME24-T66 (24X24X8)
(E6)(E7)

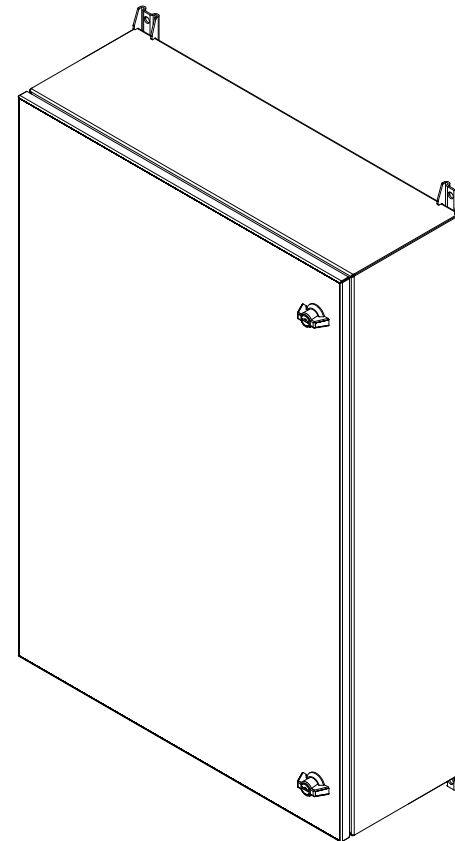

VSM-WME36-L2T18 (36X24X8)
(E2)(E3)

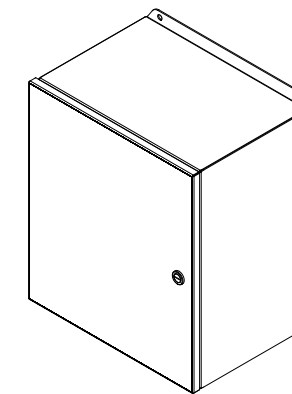

VSM-PBOX-14-12-8 (14X12X8)
(E1A)(E2A)(E3A)(E4A)

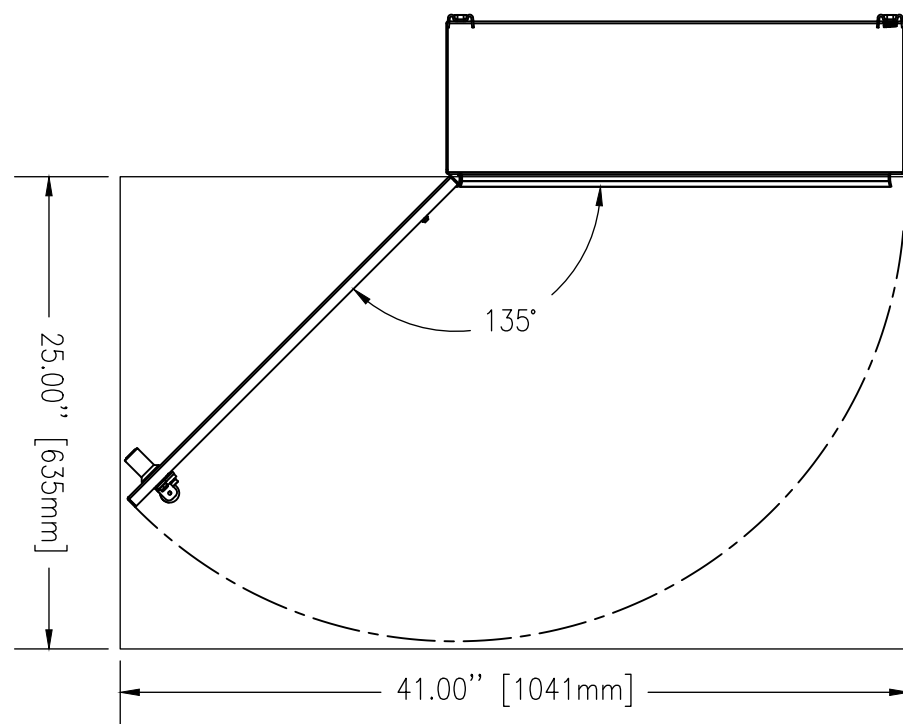

AREA REQUIRED FOR PROPER ACCESS
TO COMPONENTS AND CONNECTIONS

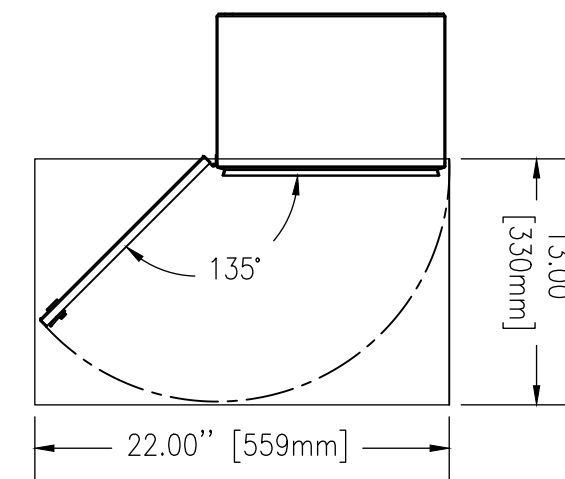

AREA REQUIRED FOR PROPER ACCESS
TO COMPONENTS AND CONNECTIONS

CADREH/2023revB



© Copyright VibroSystM inc.2023

VibroSystM inc. reserves the right
to make changes without prior
notice to improve the product.

Section: C

Product number:
VSM-CAB-MINE1-100

MECHANICAL

Drawing number:
VSM-DWG-MINE1-100

Sheet: Rev. :
C6 1

Title: ZOOM MONITORING SYSTEM FOR PROJECT: YOUR MINING SITE
JUNCTION BOXES AREA REQUIRED

1

2

3

4

MATERIAL: ROOF & BASE 3mm STEEL SHEET
 PEDESTAL 3mm U PROFILE 150mmX50mm
 FINISH: SANDBLASTING PROCESS AND EPOXY PAINT

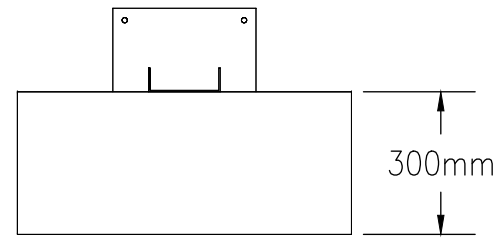

TOP VIEW

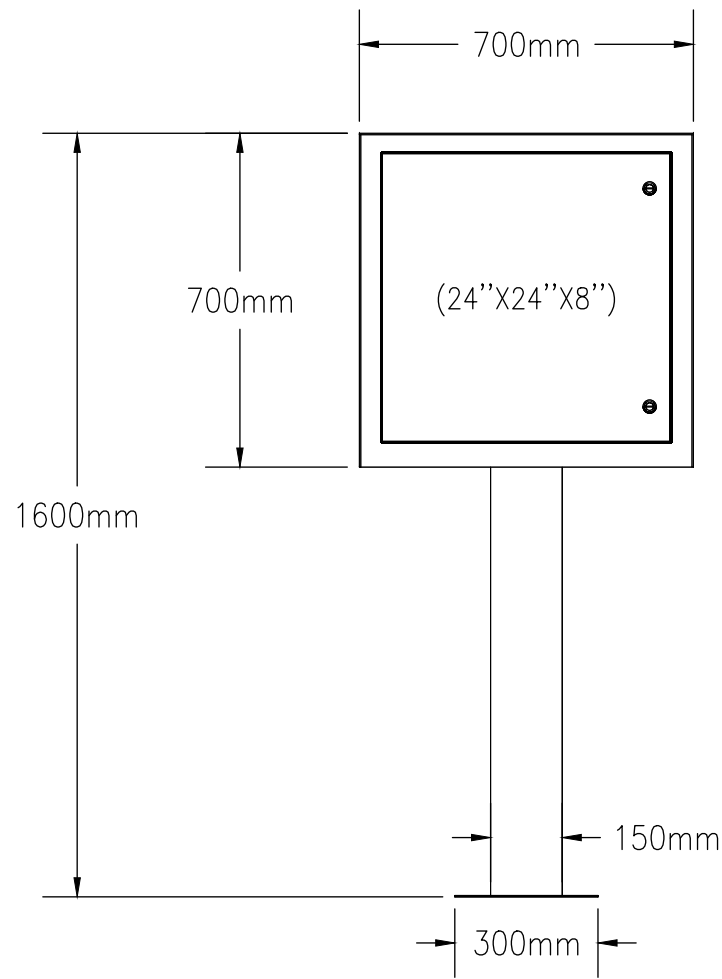

FRONT VIEW

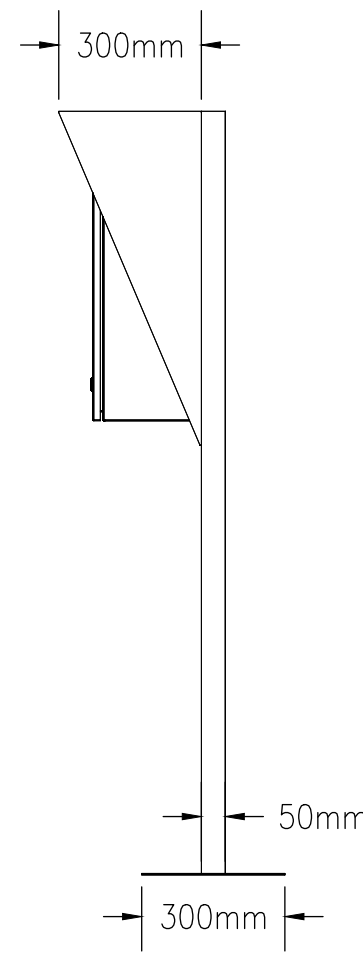

SIDE VIEW

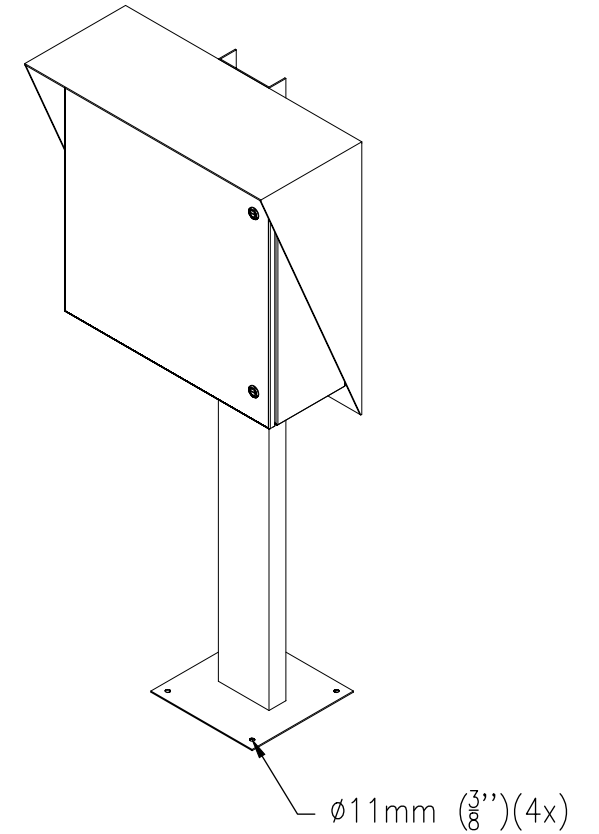

ISO VIEW

CADREB/2023revB



© Copyright VibroSystM inc.2023
 VibroSystM inc. reserves the right to make changes without prior notice to improve the product.

Section: C		MECHANICAL	
Product number: VSM-CAB-MINE1-100	Drawing number: VSM-DWG-MINE1-100	Sheet: C7	Rev. : 1

Title: ZOOM MONITORING SYSTEM FOR PROJECT: YOUR MINING SITE
 JUNCTION BOXES PEDESTAL DETAILS

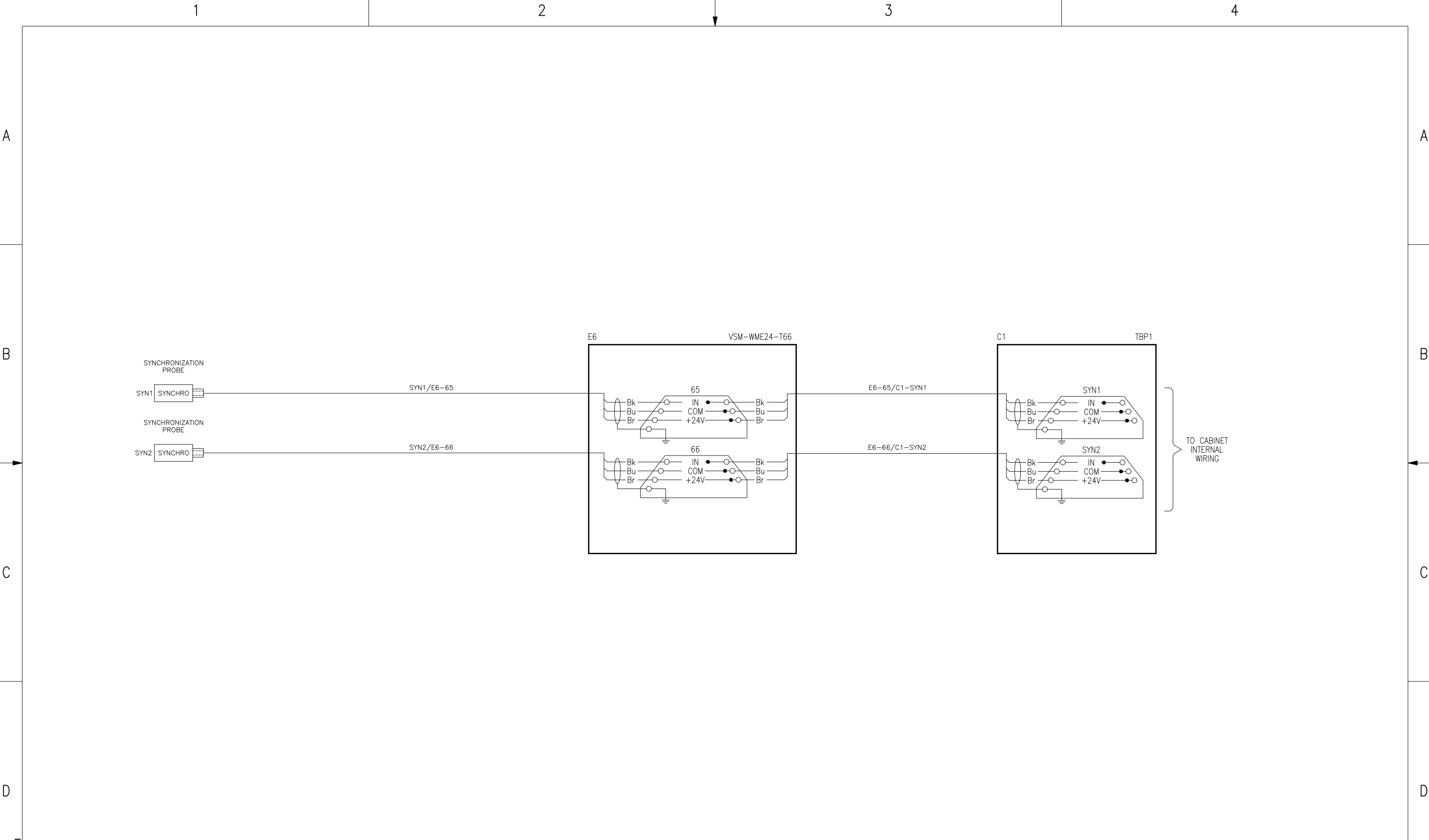

CADREB2023revB



© Copyright VibroSystM inc.2023
 VibroSystM inc. reserves the right to make changes without prior notice to improve the product.

Section: D		CABLING & WIRING	
Product number: VSM-CAB-MINE1-100	Drawing number: VSM-DWG-MINE1-100	Sheet: D1	Rev. : 1

Title: ZOOM MONITORING SYSTEM FOR PROJECT: YOUR MINING SITE
 ELECT. SCHEMATIC SYNCHRONIZATION PROBES (1-2)

A

A

B

B

C

C

D

D

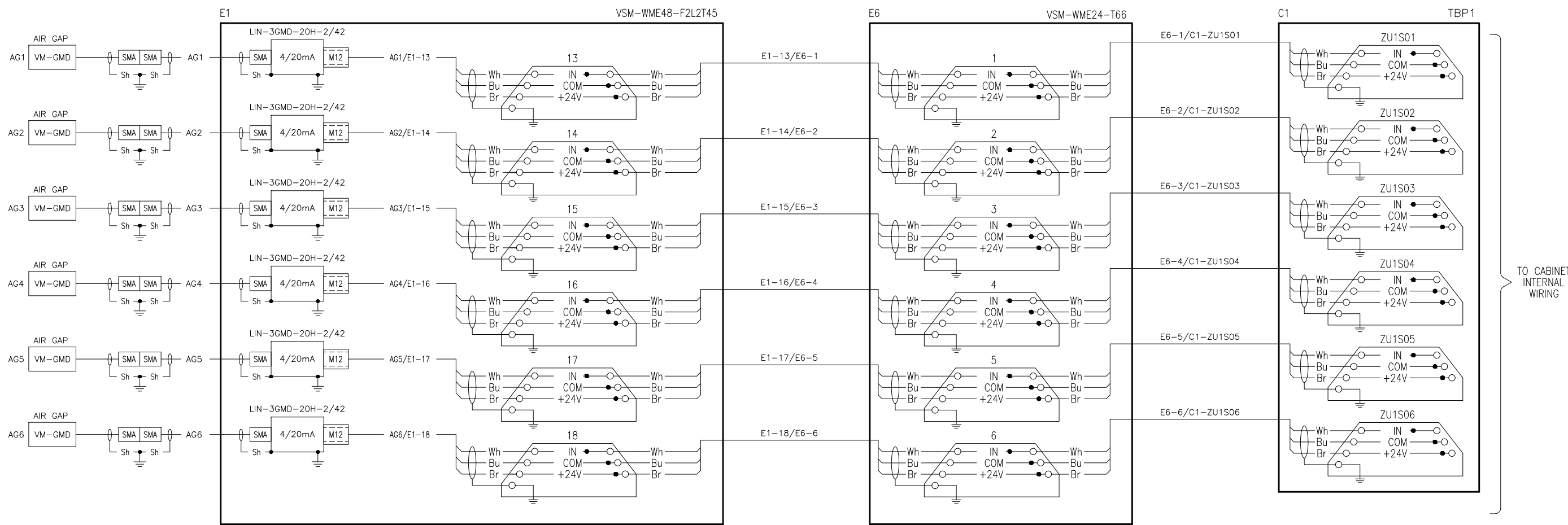

CADREB2023revB



© Copyright VibroSystM inc.2023
 VibroSystM inc. reserves the right to make changes without prior notice to improve the product.

Section: D		CABLING & WIRING	
Product number: VSM-CAB-MINE1-100	Drawing number: VSM-DWG-MINE1-100	Sheet: D2	Rev. : 1

Title: ZOOM MONITORING SYSTEM FOR PROJECT: YOUR MINING SITE
 ELECT. SCHEMATIC AIR GAP MEASURING CHAINS (AG1-AG6)

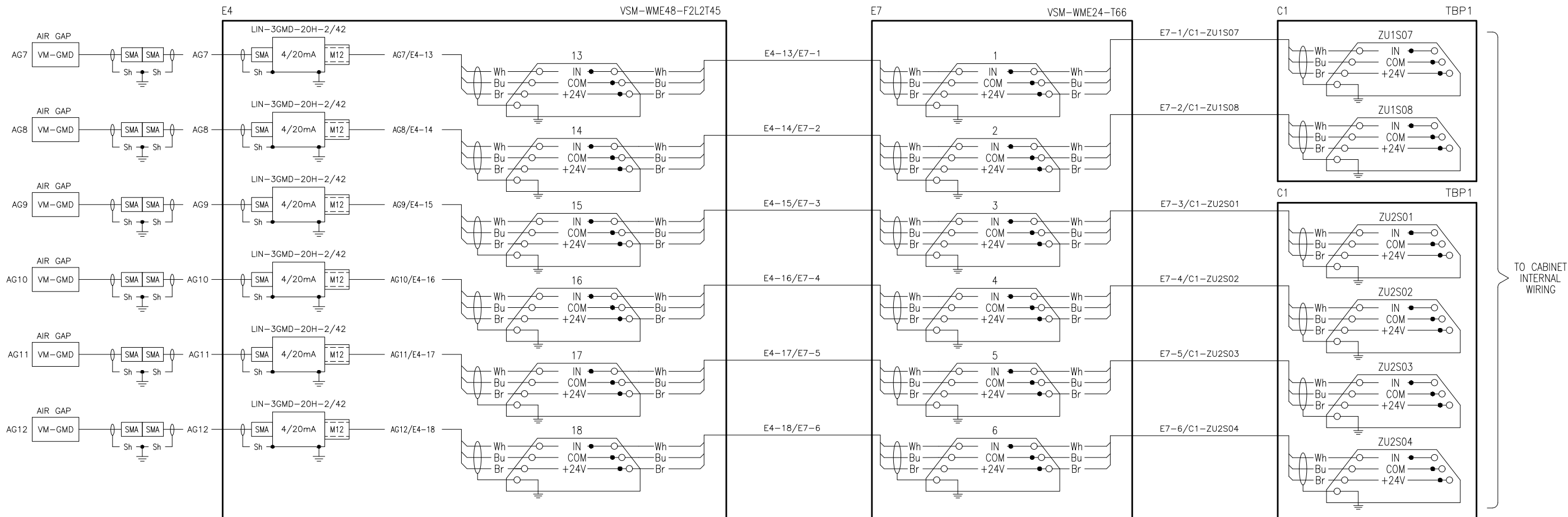

A

A

B

B

C

C

D

D

CADREB2023revB



© Copyright VibroSystM inc.2023
 VibroSystM inc. reserves the right to make changes without prior notice to improve the product.

Section: D
 Product number:
 VSM-CAB-MINE1-100

CABLING & WIRING
 Drawing number:
 VSM-DWG-MINE1-100
 Sheet: D3
 Rev. : 1

Title: ZOOM MONITORING SYSTEM FOR PROJECT: YOUR MINING SITE
 ELECT. SCHEMATIC AIR GAP MEASURING CHAINS (AG7-AG12)

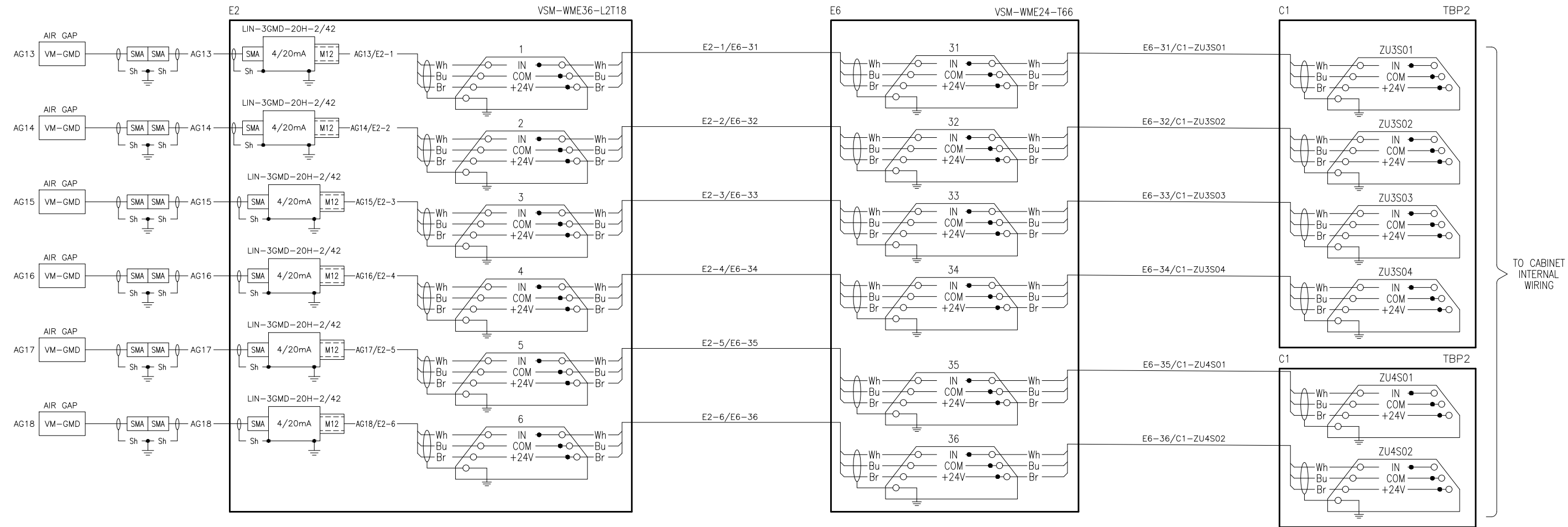

CADREH2023revB



© Copyright VibroSystem inc. 2023
 VibroSystem inc. reserves the right to make changes without prior notice to improve the product.

Section: D		CABLING & WIRING	
Product number: VSM-CAB-MINE1-100	Drawing number: VSM-DWG-MINE1-100	Sheet: D4	Rev. : 1

Title: ZOOM MONITORING SYSTEM FOR PROJECT: YOUR MINING SITE
 ELECT. SCHEMATIC AIR GAP MEASURING CHAINS (AG13-AG18)

1

2

3

4

A

A

B

B

C

C

D

D

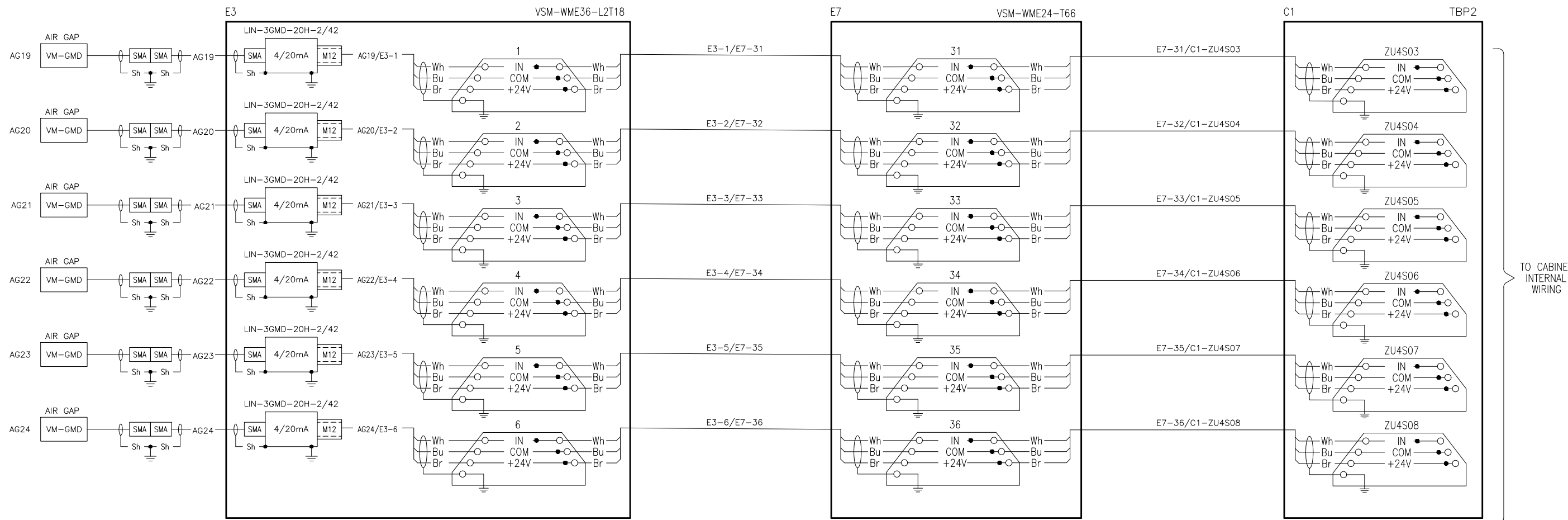

TO CABINET INTERNAL WIRING

CADREB/2023revB



© Copyright VibroSystem inc. 2023
 VibroSystem inc. reserves the right to make changes without prior notice to improve the product.

Section: D
 Product number: VSM-CAB-MINE1-100
 CABLING & WIRING
 Drawing number: VSM-DWG-MINE1-100
 Sheet: D5 Rev.: 1

Title: ZOOM MONITORING SYSTEM FOR PROJECT: YOUR MINING SITE
 ELECT. SCHEMATIC AIR GAP MEASURING CHAINS (AG19-AG24)

1

2

3

4

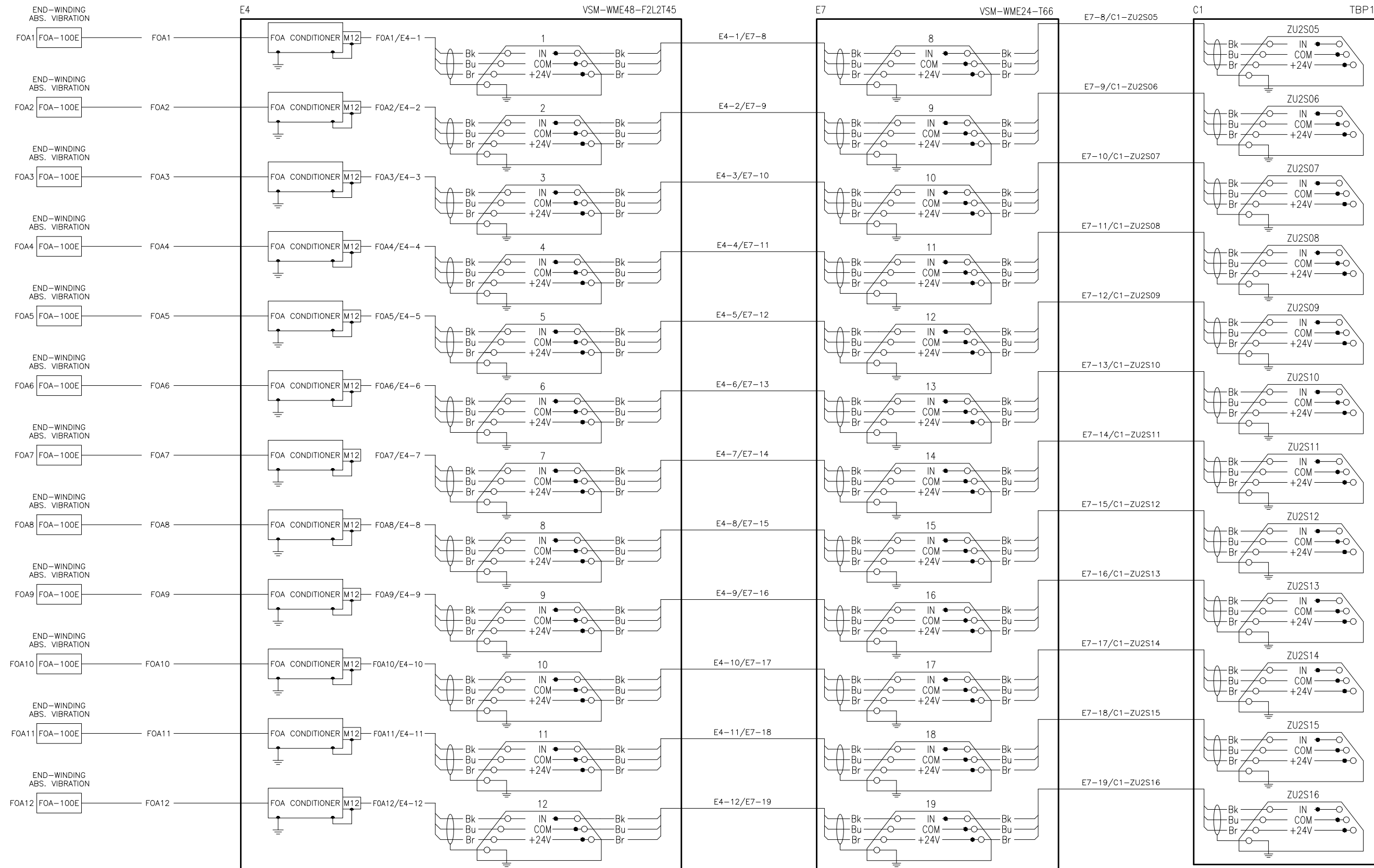

A

A

B

B

C

C

D

D

CADREB2023revB



© Copyright VibroSystM inc.2023
 VibroSystM inc. reserves the right to make changes without prior notice to improve the product.

Section: D
 Product number:
 VSM-CAB-MINE1-100

CABLING & WIRING
 Drawing number:
 VSM-DWG-MINE1-100

Sheet: D6
 Rev. : 1

Title: ZOOM MONITORING SYSTEM FOR PROJECT: YOUR MINING SITE
 ELECT. SCHEMATIC END-WINDING MEASURING CHAINS (FOA1-FOA12)

1

2

3

4

A

A

B

B

C

C

D

D

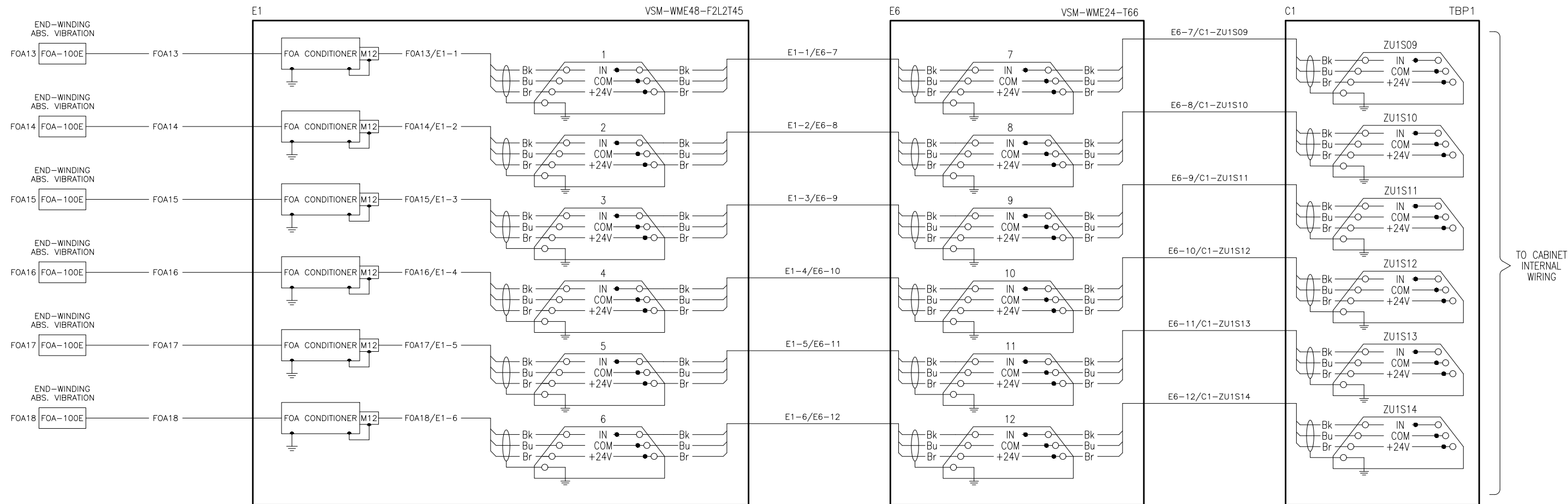

CADREB2023revB



© Copyright VibroSystM inc. 2023
 VibroSystM inc. reserves the right to make changes without prior notice to improve the product.

Section: D		CABLING & WIRING		Title: ZOOM MONITORING SYSTEM FOR PROJECT: YOUR MINING SITE	
Product number: VSM-CAB-MINE1-100	Drawing number: VSM-DWG-MINE1-100	Sheet: D7	Rev. : 1	ELECT. SCHEMATIC END-WINDING MEASURING CHAINS (FOA13-FOA18)	

1

2

3

4

1

2

3

4

A

A

B

B

C

C

D

D

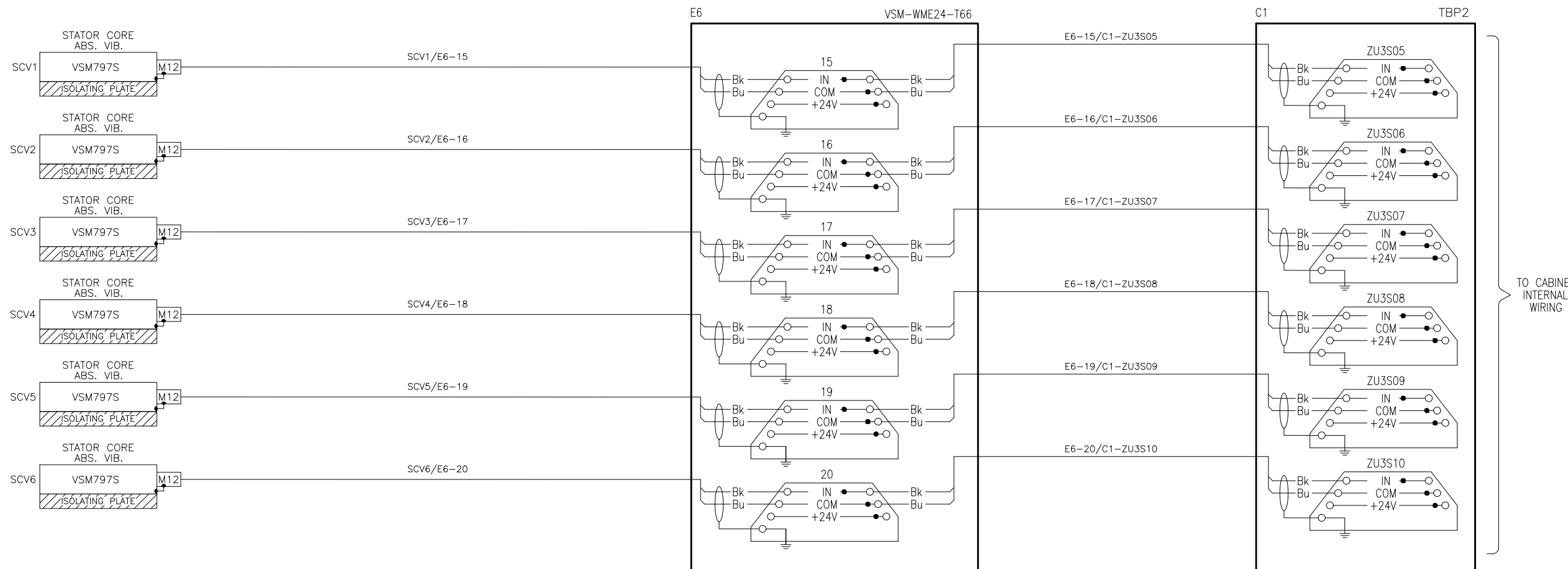

CADREB2023revB



© Copyright VibroSystM inc.2023

VibroSystM inc. reserves the right to make changes without prior notice to improve the product.

Section: D

Product number: VSM-CAB-MINE1-100

CABLING & WIRING

Drawing number: VSM-DWG-MINE1-100

Sheet: D8 Rev. : 1

Title: ZOOM MONITORING SYSTEM FOR PROJECT: YOUR MINING SITE
ELECT. SCHEMATIC STATOR CORE MEASURING CHAINS (SCVx)

1

2

3

4

VSM-DWG-MINE1-100-D8-1.DWG

1

2

3

4

A

A

B

B

C

C

D

D

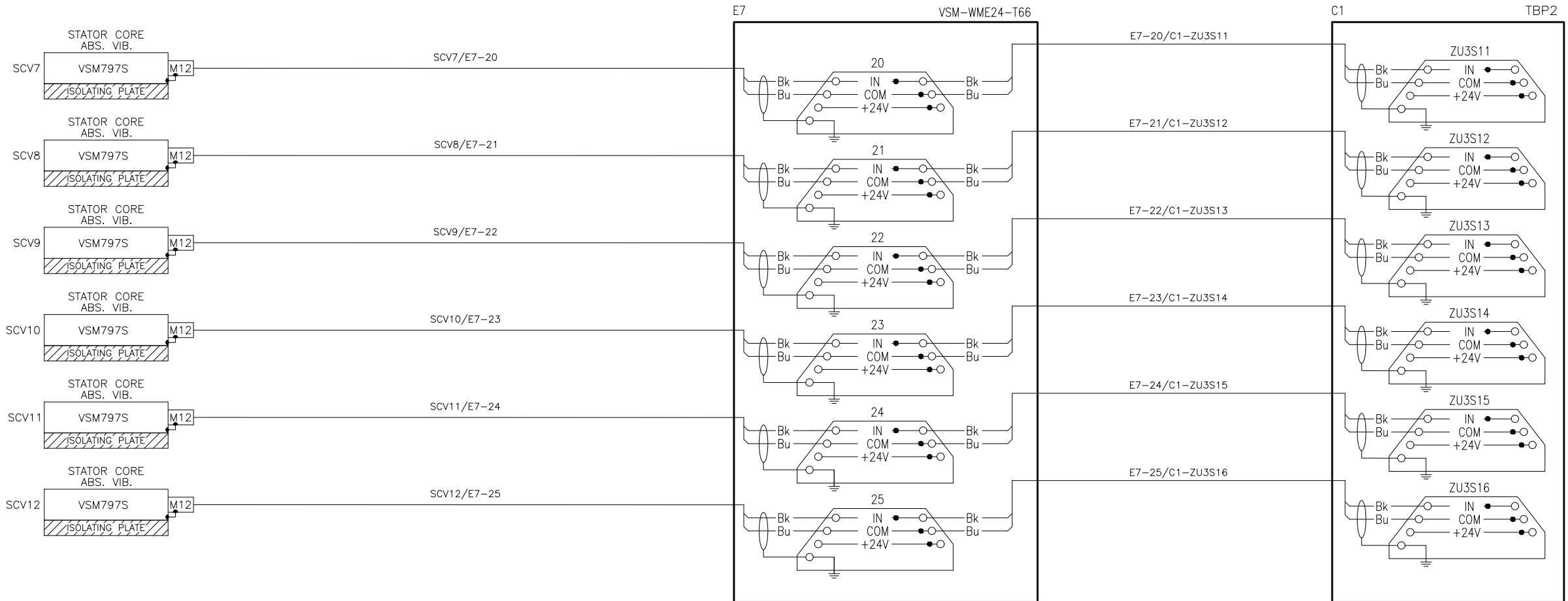

TO CABINET INTERNAL WIRING

CADREB2023revB



© Copyright VibroSystM inc.2023
 VibroSystM inc. reserves the right to make changes without prior notice to improve the product.

Section: D
 Product number: VSM-CAB-MINE1-100
 Drawing number: VSM-DWG-MINE1-100
 Sheet: D9
 Rev.: 1

Title: ZOOM MONITORING SYSTEM FOR PROJECT: YOUR MINING SITE
 ELECT. SCHEMATIC STATOR CORE MEASURING CHAINS (SCVx)

1

2

3

4

VSM-DWG-MINE1-100-D9-1.DWG

1

2

3

4

A

A

B

B

C

C

D

D

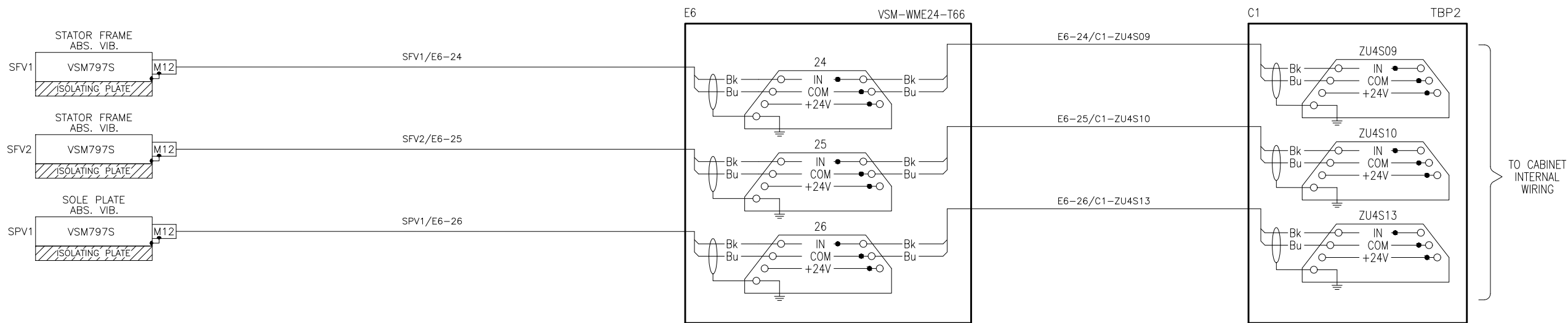

CADREB2023revB



© Copyright VibroSystM inc.2023

VibroSystM inc. reserves the right to make changes without prior notice to improve the product.

Section: D

Product number: VSM-CAB-MINE1-100

CABLING & WIRING

Drawing number: VSM-DWG-MINE1-100

Sheet: D10 Rev. : 1

Title: ZOOM MONITORING SYSTEM FOR PROJECT: YOUR MINING SITE
ELECT. SCHEMATIC STATOR FRAME MEASURING CHAINS (SFVx & SPVx)

1

2

3

4

1

2

3

4

A

A

B

B

C

C

D

D

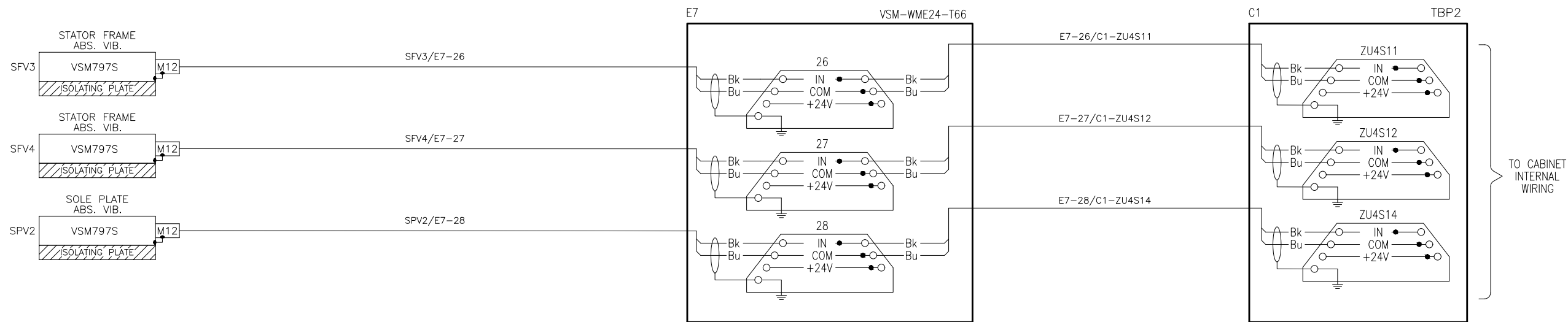

CADREB2023revB



© Copyright VibroSystM inc.2023

VibroSystM inc. reserves the right to make changes without prior notice to improve the product.

Section: D

Product number: VSM-CAB-MINE1-100

CABLING & WIRING

Drawing number: VSM-DWG-MINE1-100

Sheet: D11 Rev. : 1

Title: ZOOM MONITORING SYSTEM FOR PROJECT: YOUR MINING SITE
ELECT. SCHEMATIC STATOR FRAME MEASURING CHAINS (SFVx & SPVx)

1

2

3

4

1

2

3

4

A

A

B

B

C

C

D

D

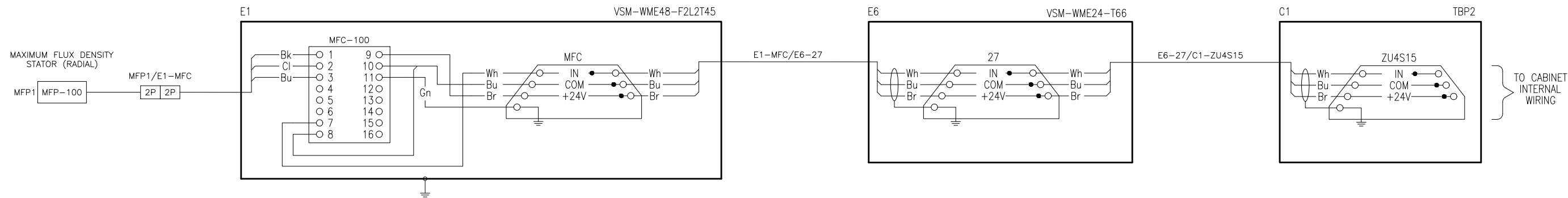

CADREB2023revB



© Copyright VibroSystM inc. 2023
 VibroSystM inc. reserves the right to make changes without prior notice to improve the product.

Section: D		CABLING & WIRING	
Product number:	VSM-CAB-MINE1-100	Drawing number:	VSM-DWG-MINE1-100
Sheet:	D12	Rev. :	1

Title: ZOOM MONITORING SYSTEM FOR PROJECT: YOUR MINING SITE
 ELECT. SCHEMATIC MAGNETIC FLUX DENSITY MEASURING CHAIN

1

2

3

4

A
B
C
D

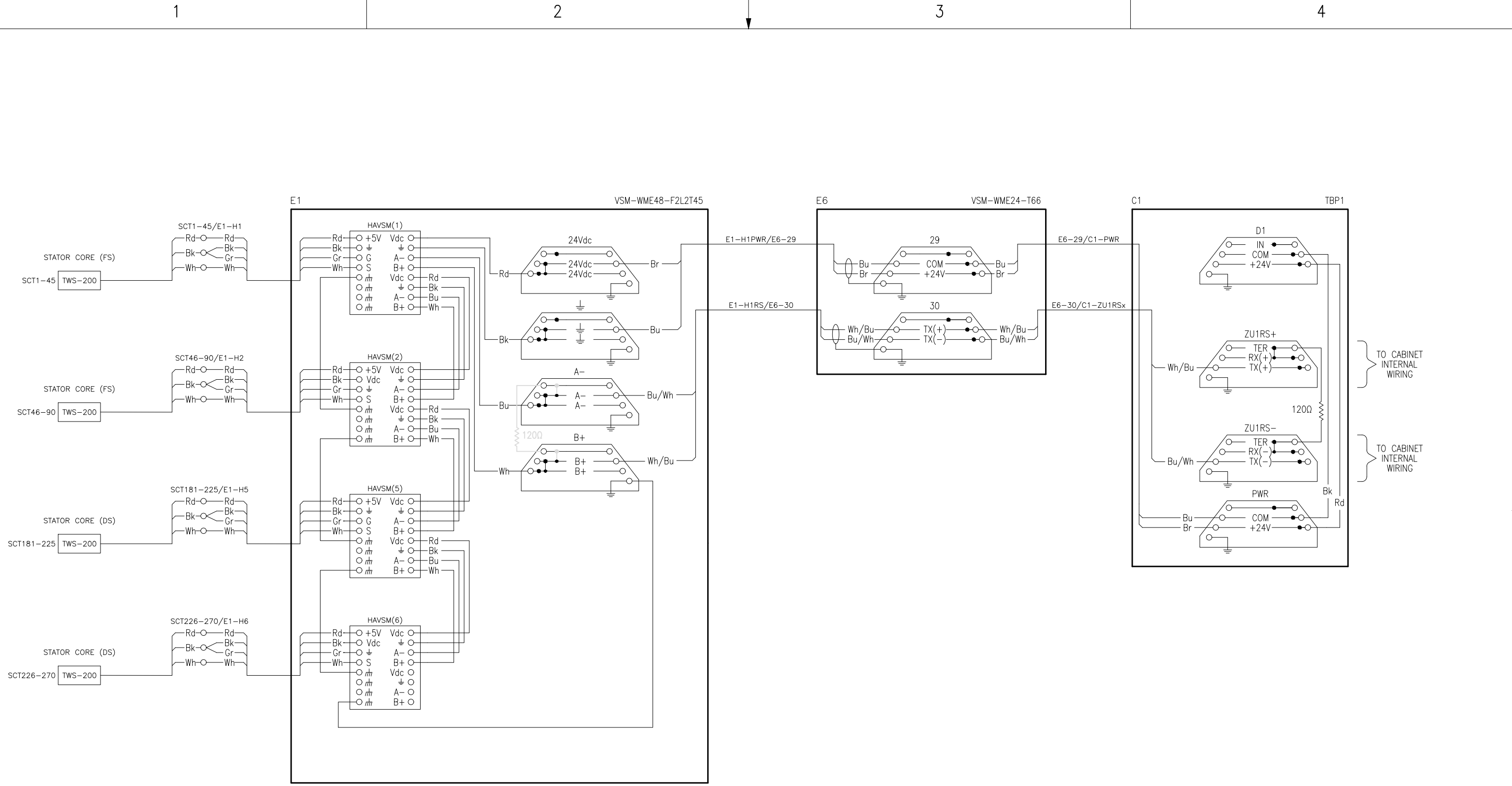

CADREH2023revB



© Copyright VibroSystem inc. 2023
VibroSystem inc. reserves the right to make changes without prior notice to improve the product.

Section: D
Product number: VSM-CAB-MINE1-100
Drawing number: VSM-DWG-MINE1-100
Sheet: D13
Rev.: 1

Title: ZOOM MONITORING SYSTEM FOR PROJECT: YOUR MINING SITE
ELECT. SCHEMATIC THERMAWATCH STATOR MEASURING CHAINS

A
B
C
D

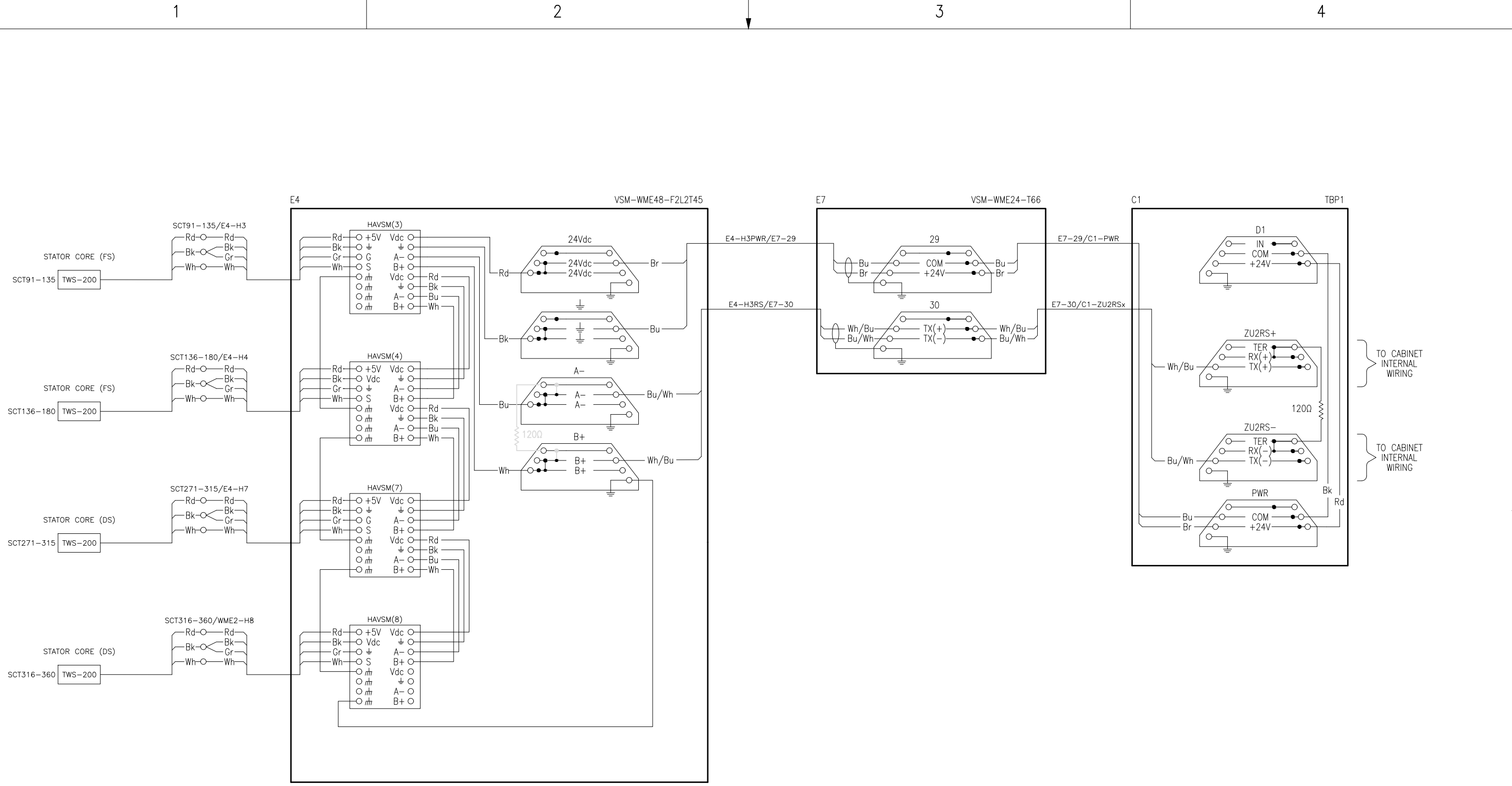

CADREH2023revB



© Copyright VibroSystem inc. 2023
VibroSystem inc. reserves the right to make changes without prior notice to improve the product.

Section: D
Product number: VSM-CAB-MINE1-100
Drawing number: VSM-DWG-MINE1-100
Sheet: D14
Rev.: 1

Title: ZOOM MONITORING SYSTEM FOR PROJECT: YOUR MINING SITE
ELECT. SCHEMATIC THERMAWATCH STATOR MEASURING CHAINS

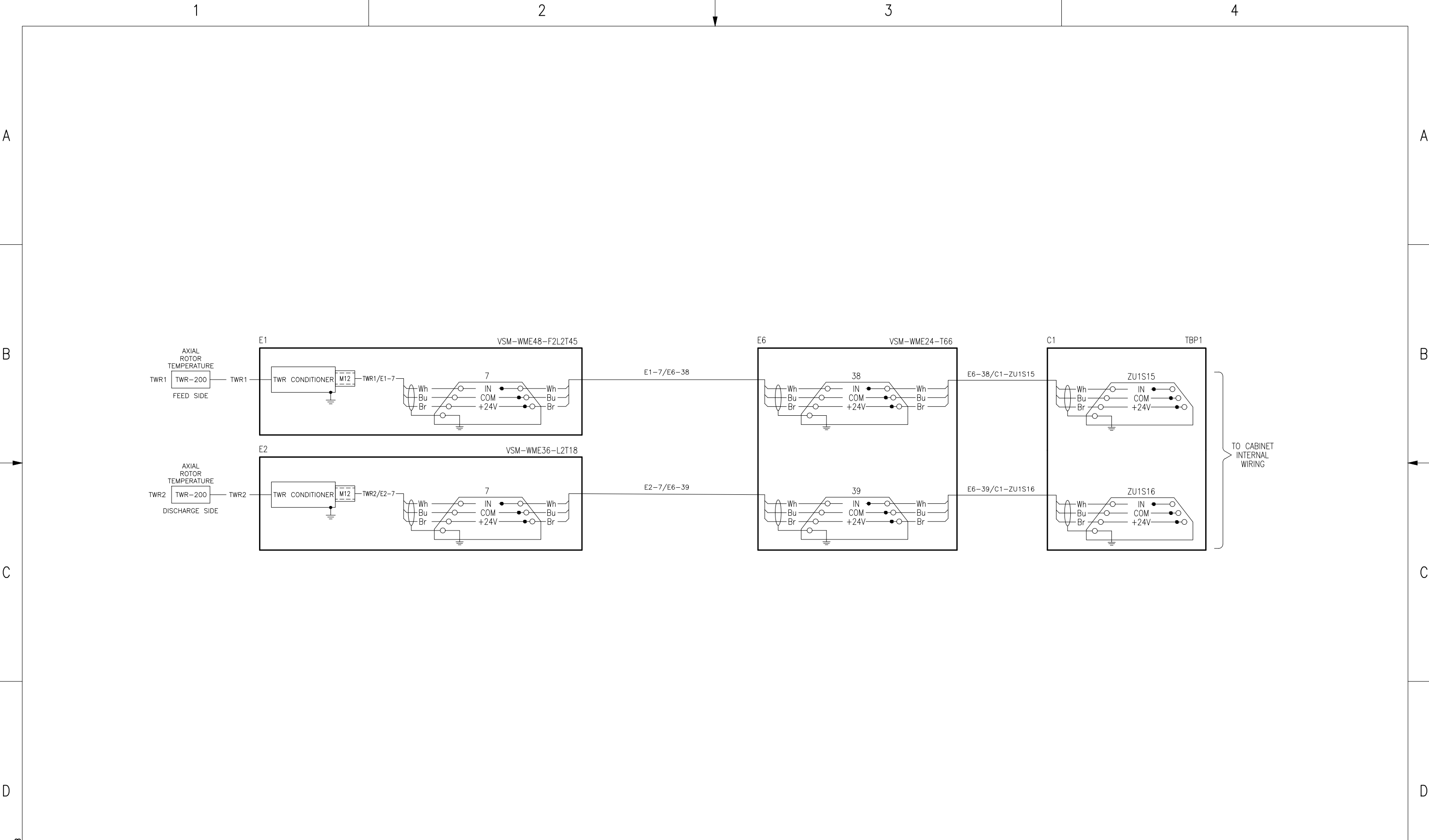

CADREB2023revB



© Copyright VibroSystem inc. 2023
 VibroSystem inc. reserves the right to make changes without prior notice to improve the product.

Section: D		CABLING & WIRING	
Product number:	VSM-CAB-MINE1-100	Drawing number:	VSM-DWG-MINE1-100
Sheet:	D15	Rev. :	1

Title: ZOOM MONITORING SYSTEM FOR PROJECT: YOUR MINING SITE
 ELECT. SCHEMATIC ROTOR TEMPERATURE MEASURING CHAINS

1

2

3

4

A

A

B

B

C

C

D

D

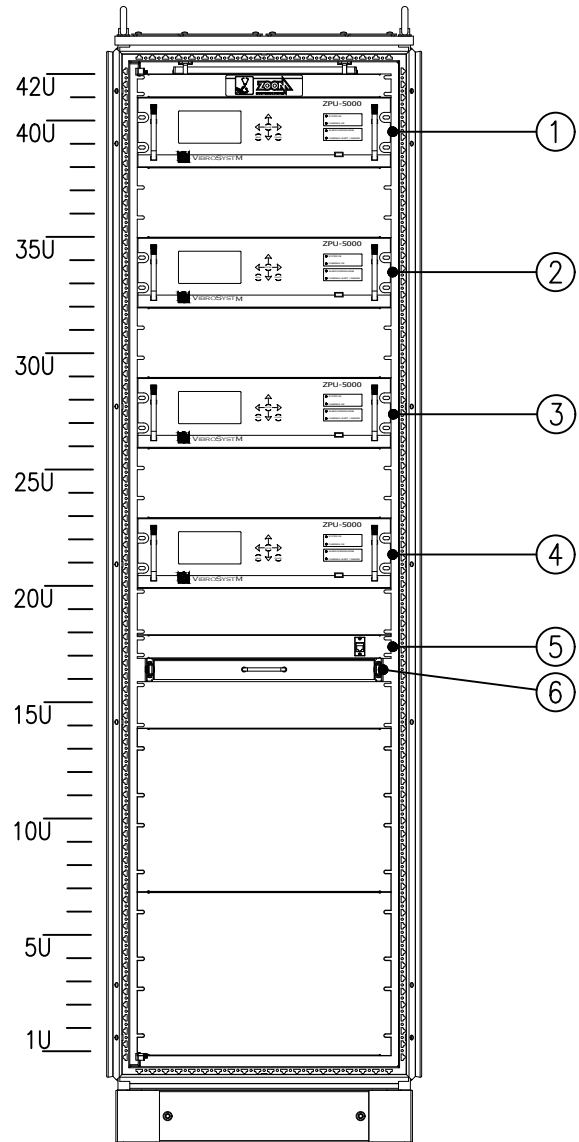

FRONT VIEW

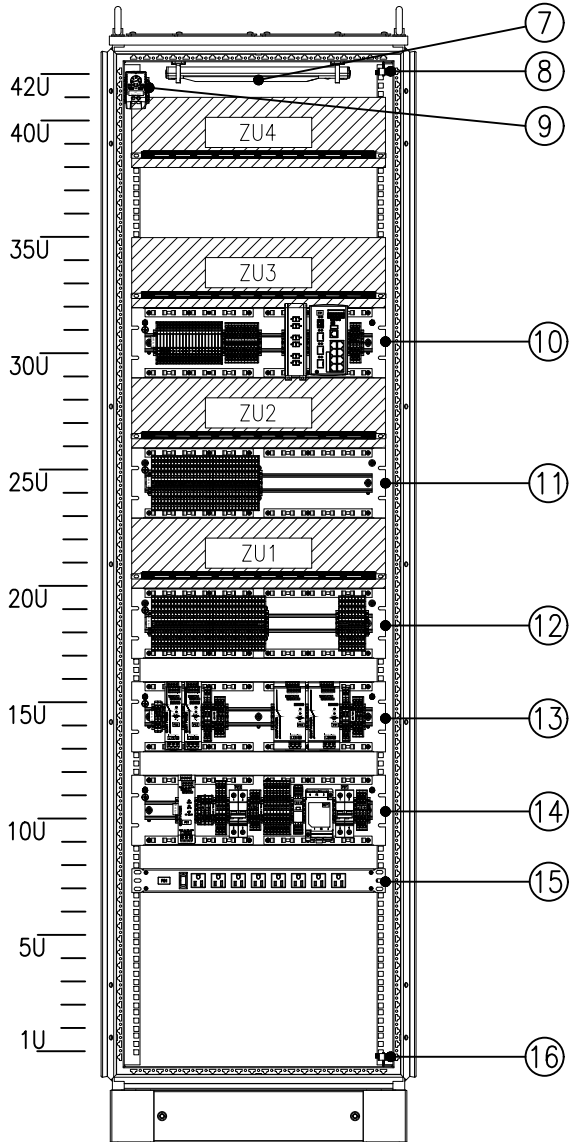

REAR VIEW

EQUIPMENTS

FRONT VIEW OF CABINET

- 1- ZPU-5000 (ZU4)
- 2- ZPU-5000 (ZU3)
- 3- ZPU-5000 (ZU2)
- 4- ZPU-5000 (ZU1)
- 5- RJ-45 PANEL
- 6- ROLL OUT SHELF

REAR VIEW OF CABINET

- 7- LIGHT FIXTURE (LT1)
- 8- PROTECTIVE CONDUCTOR TERMINAL (PCT2)
- 9- THERMOSTAT HT (HT1)
- 10- F/O ETHERNET & ALARM RELAY PANEL (ERP1)
- 11- TERMINAL BLOCKS PANEL (TBP2)
- 12- TERMINAL BLOCKS PANEL (TBP1)
- 13- LOW VOLTAGE SUPPLY PANEL REDUNDANCY (PSP1)
- 14- MAIN POWER PANEL (MAP1)
- 15- MULTI-OUTLET TYPE "B" (PB1)
- 16- PROTECTIVE CONDUCTOR TERMINAL (PCT1)

1U=1.75" OR 44.45mm

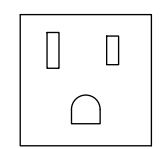

ELECTRICAL OUTLET TYPE "B" (PB1)

CADREBH2023revB



© Copyright VibroSystM inc.2023
 VibroSystM inc. reserves the right to make changes without prior notice to improve the product.

Section: E ZOOM MONITORING CABINET INTERNAL COMPONENTS & WIRING		Title: ZOOM MONITORING SYSTEM FOR PROJECT: YOUR MINING SITE MONITORING CABINET EQUIPMENT	
Product number: VSM-CAB-MINE1-100	Drawing number: VSM-DWG-MINE1-100	Sheet: E1	Rev. : 1

1

2

3

4

WARNING MAINTAINING DATA INTEGRITY IS CRITICAL FOR MONITORING AND PROTECTION OF THE MACHINE(S). USE DEDICATED (15A) CIRCUIT BREAKER OR EQUIVALENT TO POWER INPUT OF THE CABINET.

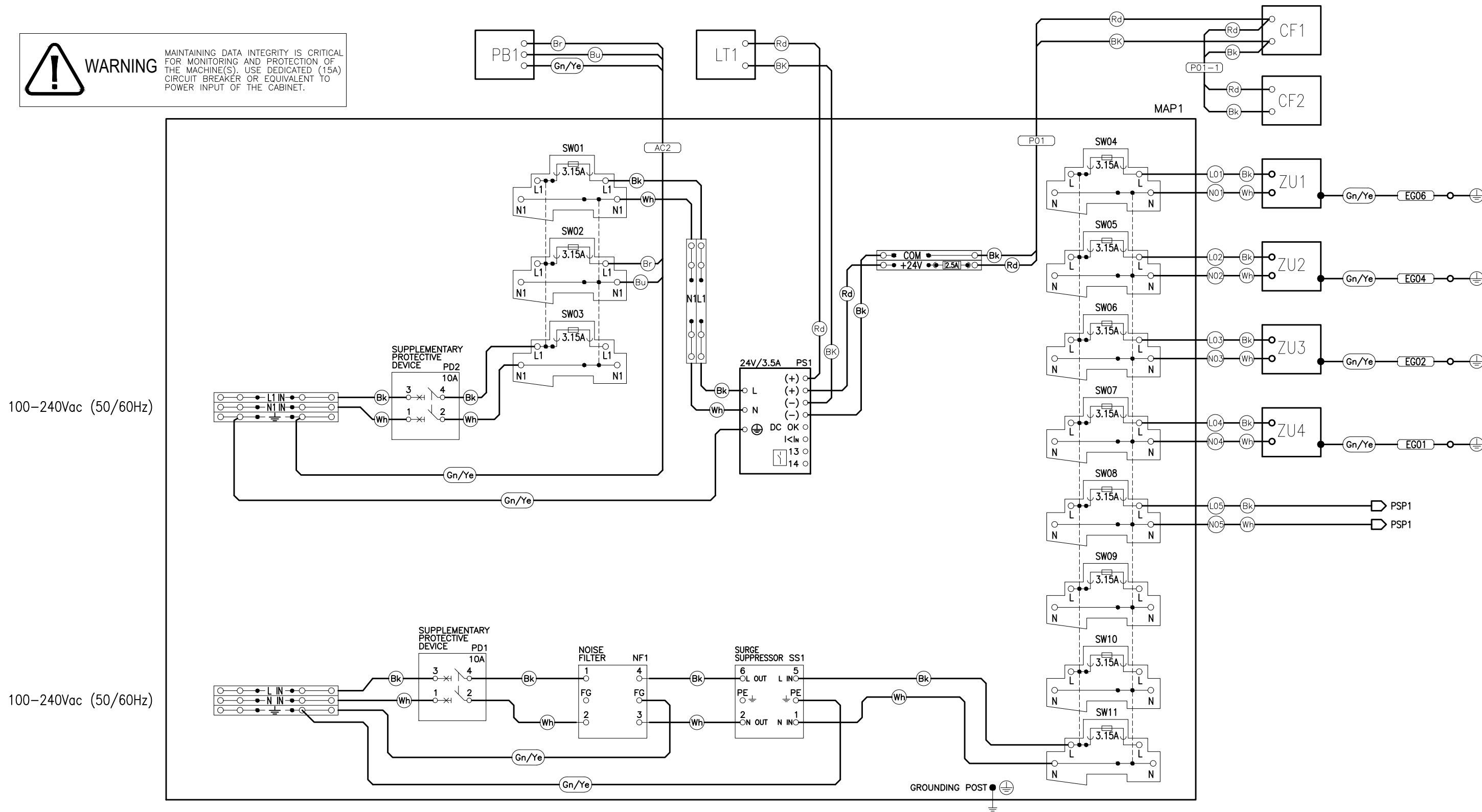

CADREH2023revB



© Copyright VibroSystM inc.2023
 VibroSystM inc. reserves the right to make changes without prior notice to improve the product.

Section: E ZOOM MONITORING CABINET INTERNAL COMPONENTS & WIRING
 Product number: VSM-CAB-MINE1-100
 Drawing number: VSM-DWG-MINE1-100
 Sheet: E2 Rev.: 1

Title: ZOOM MONITORING SYSTEM FOR PROJECT: YOUR MINING SITE
 ELECT. SCHEMATIC MAIN & AUXILIARY SUPPLY (MAP1)

A

A

B

B

C

C

D

D

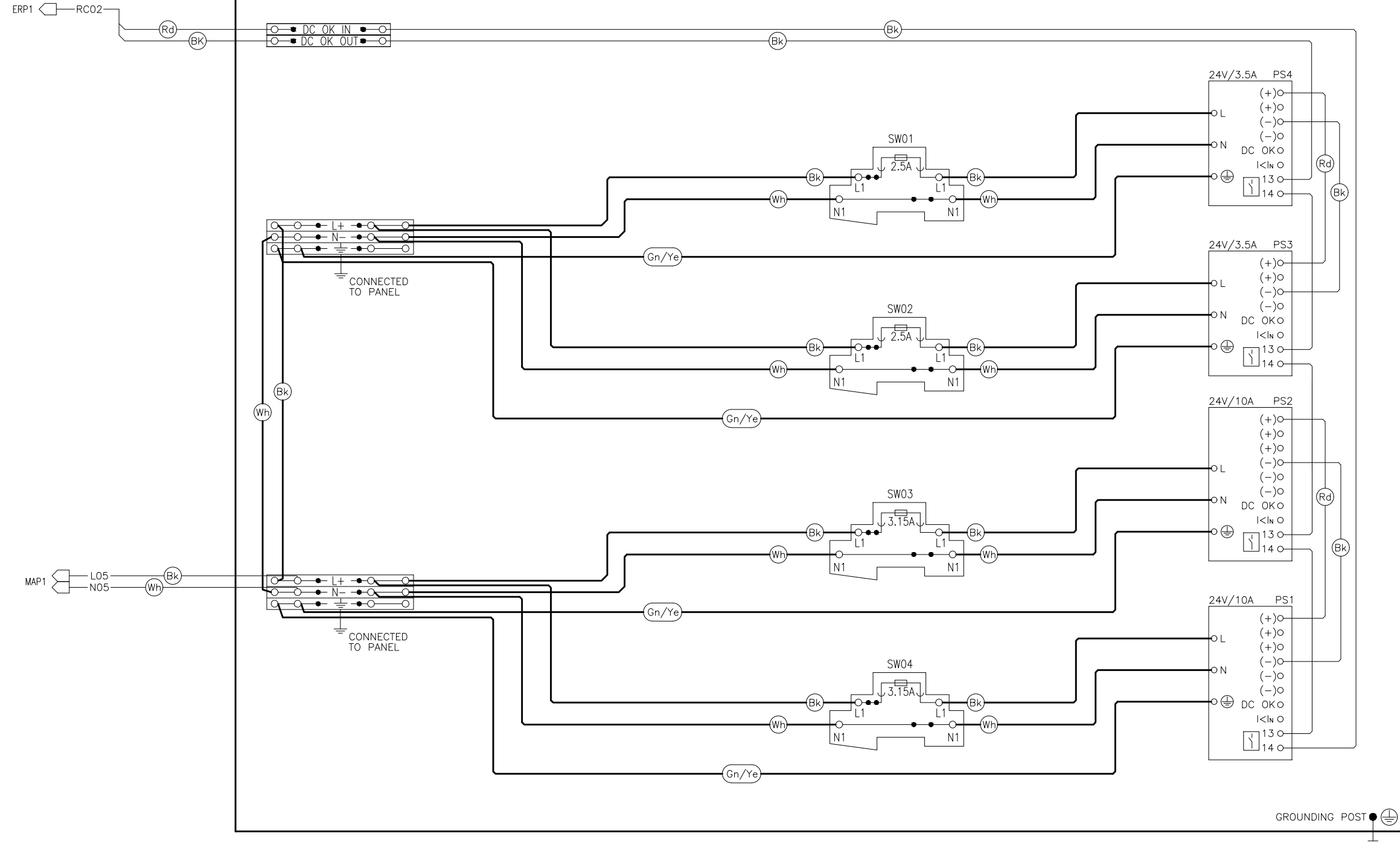

CADREB2023revB



© Copyright VibroSystM inc.2023
 VibroSystM inc. reserves the right to make changes without prior notice to improve the product.

Section: E ZOOM MONITORING CABINET INTERNAL COMPONENTS & WIRING
 Product number: VSM-CAB-MINE1-100
 Drawing number: VSM-DWG-MINE1-100
 Sheet: E3 Rev.: 1

Title: ZOOM MONITORING SYSTEM FOR PROJECT: YOUR MINING SITE
 ELECT. SCHEMATIC LOW VOLTAGE SUPPLY PANEL (PSP1)

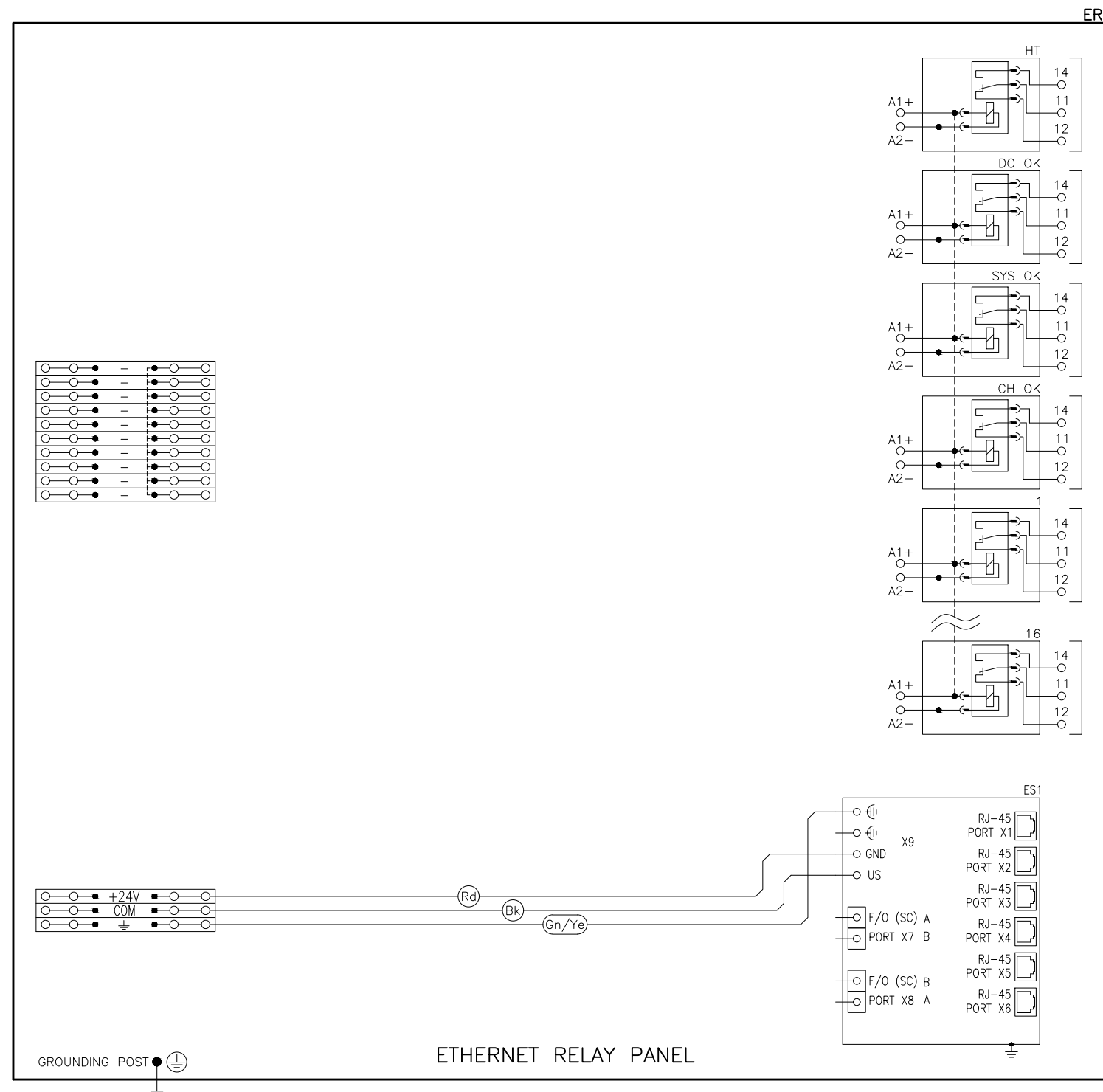

ERP1

ES1

CADREB/2023/revB



© Copyright VibroSystM inc.2023
 VibroSystM inc. reserves the right to make changes without prior notice to improve the product.

Section: E ZOOM MONITORING CABINET INTERNAL COMPONENTS & WIRING
 Product number: VSM-CAB-MINE1-100
 Drawing number: VSM-DWG-MINE1-100
 Sheet: E4 Rev.: 1

Title: ZOOM MONITORING SYSTEM FOR PROJECT: YOUR MINING SITE
 ELECT. SCHEMATIC ETHERNET & RELAY PANEL (ERP1)

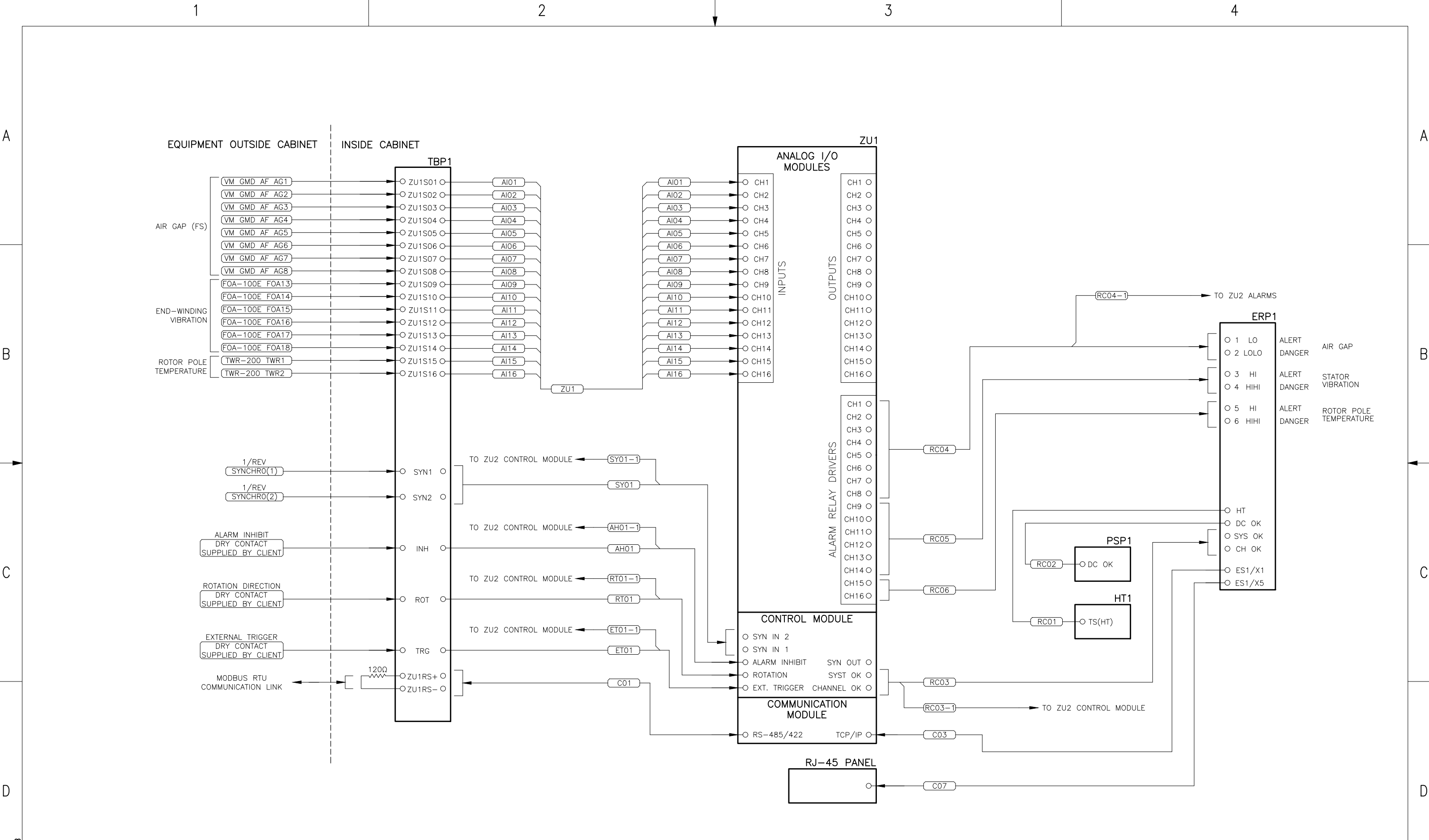

CADREH2023revB



© Copyright VibroSystM inc.2023
 VibroSystM inc. reserves the right to make changes without prior notice to improve the product.

Section: E ZOOM MONITORING CABINET INTERNAL COMPONENTS & WIRING
 Product number: VSM-CAB-MINE1-100
 Drawing number: VSM-DWG-MINE1-100
 Sheet: E5 Rev.: 1

Title: ZOOM MONITORING SYSTEM FOR PROJECT: YOUR MINING SITE
 MONITORING EQUIPMENT SCHEMATIC ZU1

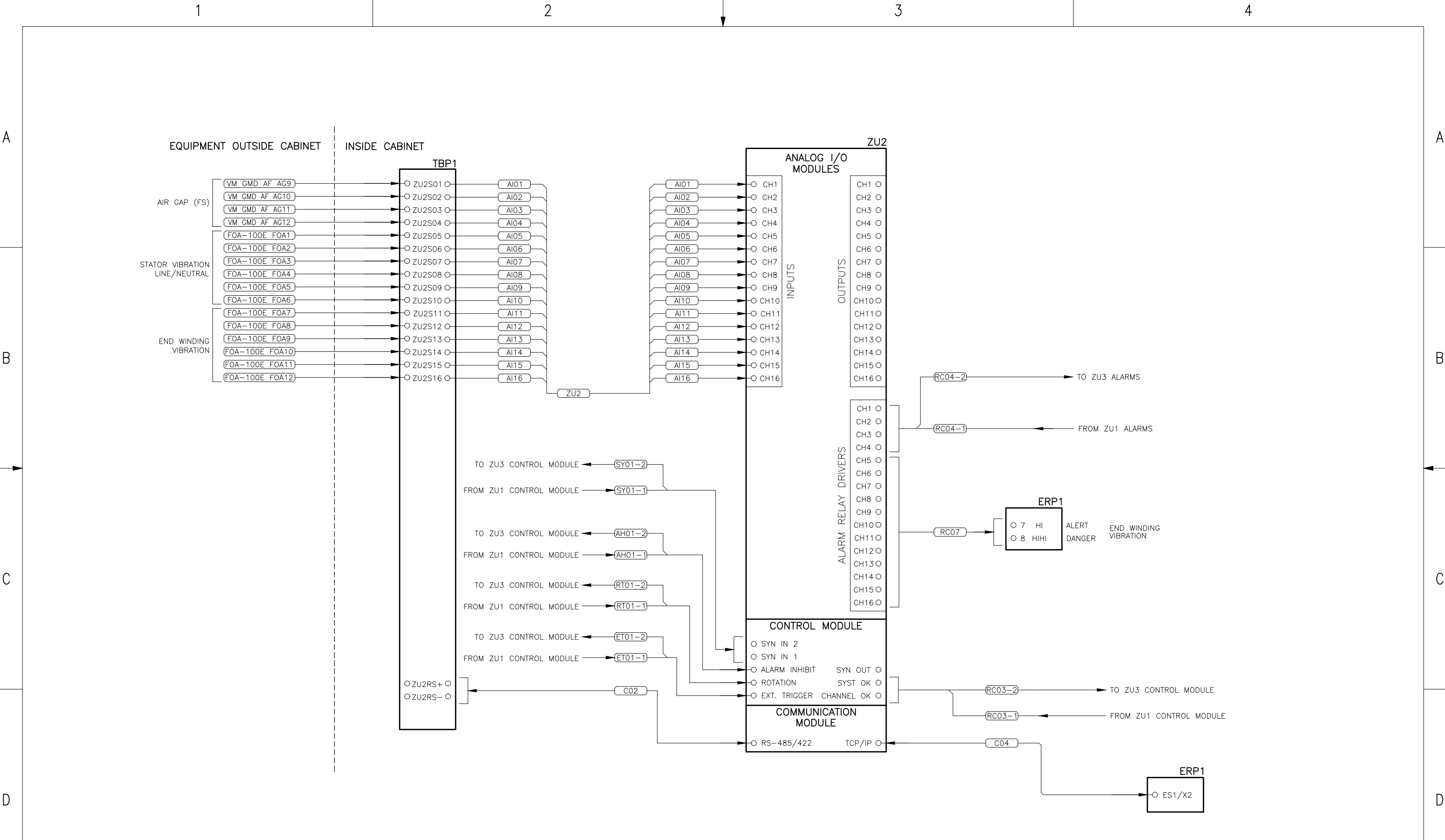

CADREH2023revB



© Copyright VibroSystM inc.2023
 VibroSystM inc. reserves the right to make changes without prior notice to improve the product.

Section: E ZOOM MONITORING CABINET INTERNAL COMPONENTS & WIRING
 Product number: VSM-CAB-MINE1-100
 Drawing number: VSM-DWG-MINE1-100
 Sheet: E6 Rev. : 1

Title: ZOOM MONITORING SYSTEM FOR PROJECT: YOUR MINING SITE
 MONITORING EQUIPMENT SCHEMATIC ZU2

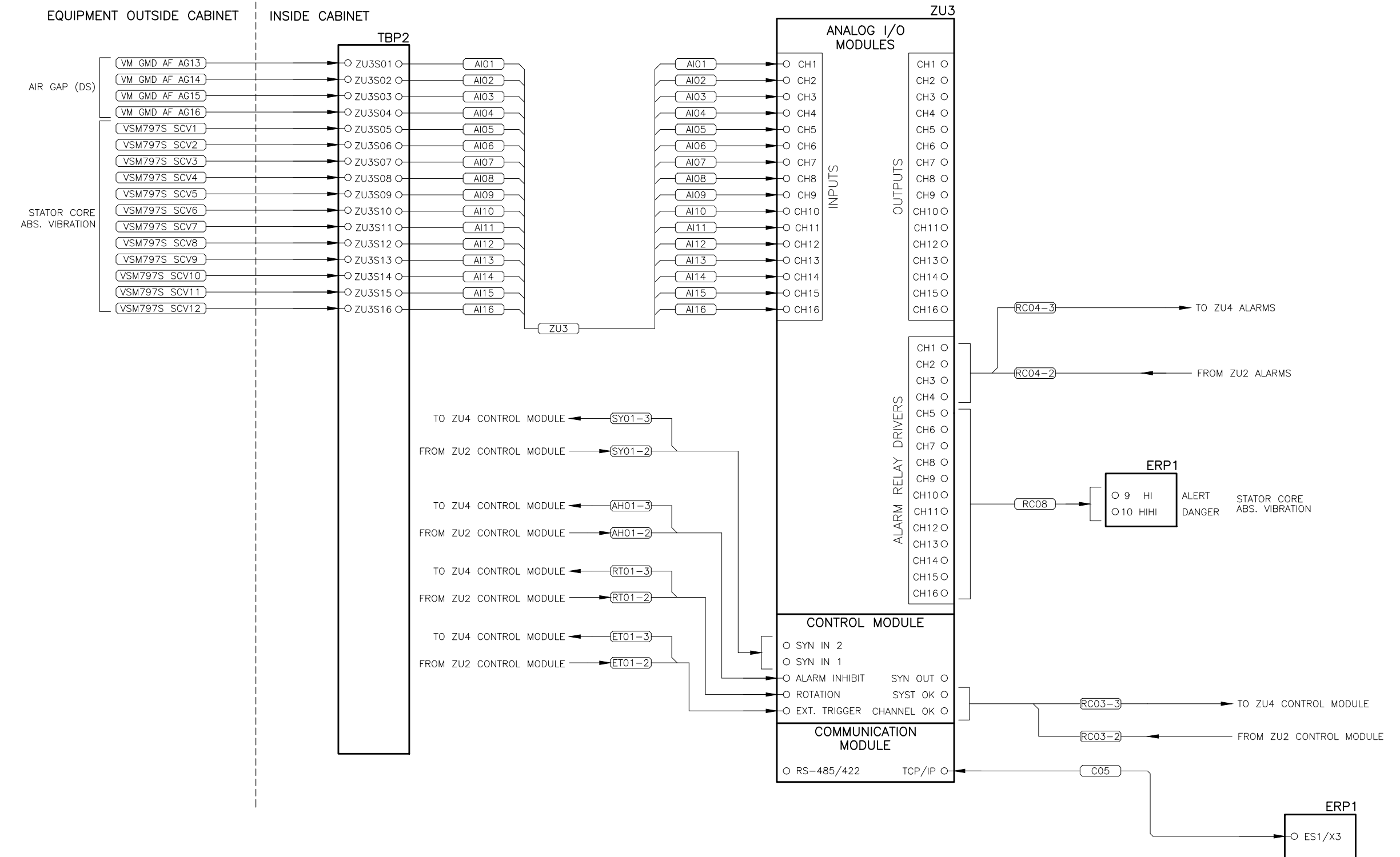

© Copyright VibroSystM inc.2023 VibroSystM inc. reserves the right to make changes without prior notice to improve the product.		Section: E ZOOM MONITORING CABINET INTERNAL COMPONENTS & WIRING		Title: ZOOM MONITORING SYSTEM FOR PROJECT: YOUR MINING SITE MONITORING EQUIPMENT SCHEMATIC ZU3	
Product number: VSM-CAB-MINE1-100		Drawing number: VSM-DWG-MINE1-100		Sheet: E7	Rev. : 1

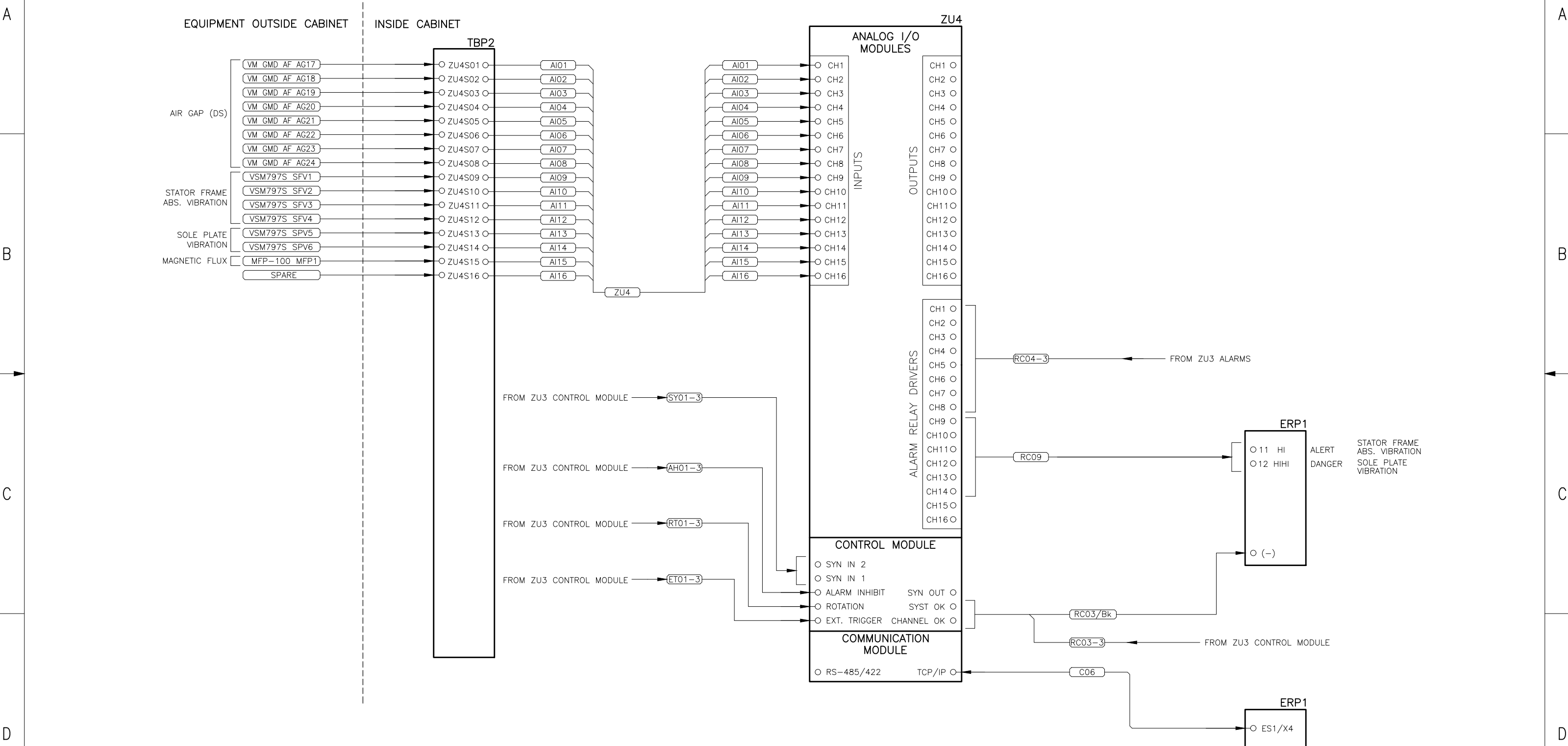

1

2

3

4

A

A

B

B

C

C

D

D

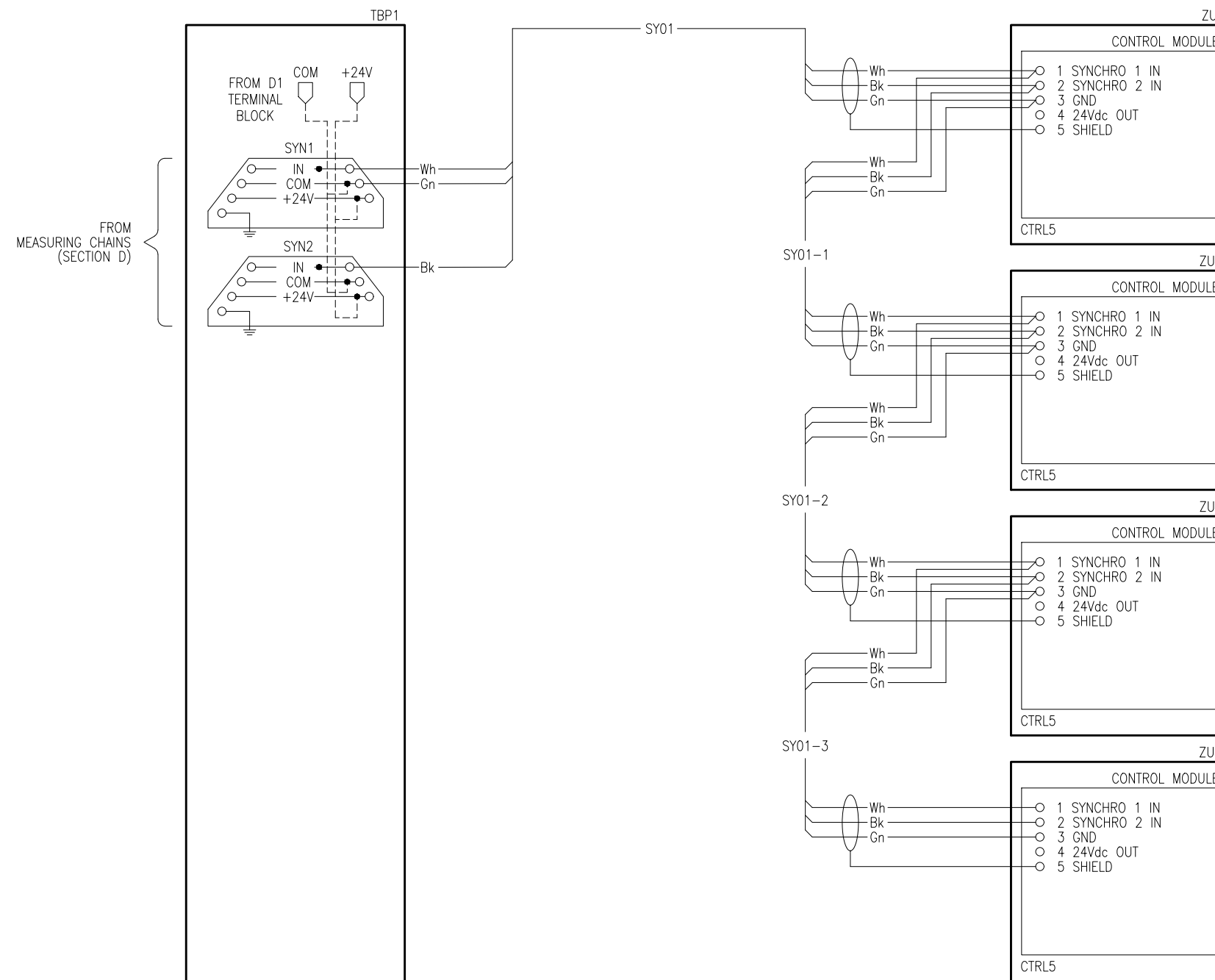

CADREB2023revB



© Copyright VibroSystM inc. 2023
 VibroSystM inc. reserves the right to make changes without prior notice to improve the product.

Section: E ZOOM MONITORING CABINET INTERNAL COMPONENTS & WIRING
 Product number: VSM-CAB-MINE1-100
 Drawing number: VSM-DWG-MINE1-100
 Sheet: E9 Rev.: 1

Title: ZOOM MONITORING SYSTEM FOR PROJECT: YOUR MINING SITE
 ELECT. SCHEMATIC SYNCHRO INPUTS

1

2

3

4

VSM-DWG-MINE1-100-E9-1.DWG

1

2

3

4

A

A

B

B

C

C

D

D

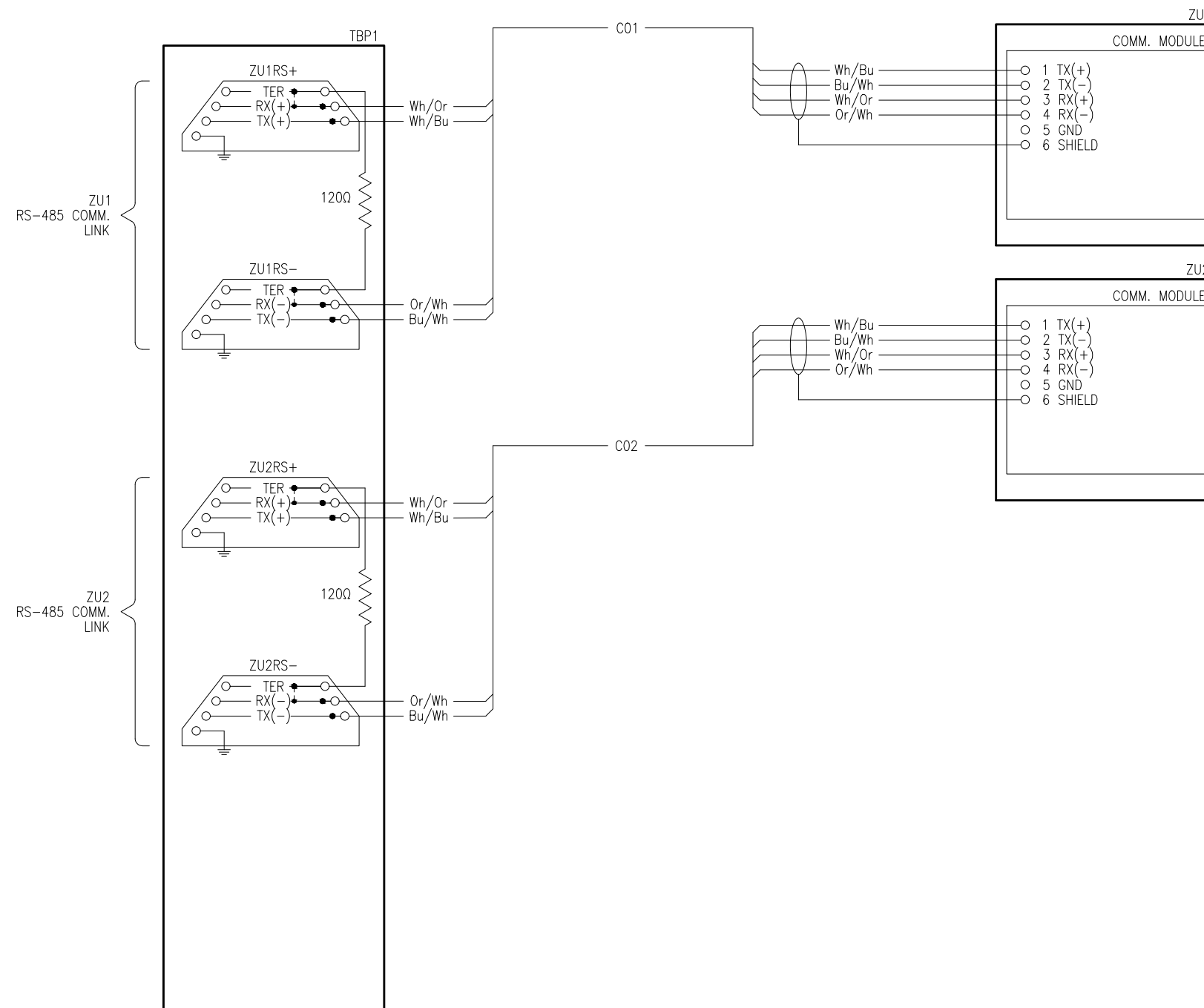

CADREB/2023revB



© Copyright VibroSystM inc.2023
 VibroSystM inc. reserves the right to make changes without prior notice to improve the product.

Section: E ZOOM MONITORING CABINET INTERNAL COMPONENTS & WIRING
 Product number: VSM-CAB-MINE1-100
 Drawing number: VSM-DWG-MINE1-100
 Sheet: E10 Rev. : 1

Title: ZOOM MONITORING SYSTEM FOR PROJECT: YOUR MINING SITE
 ELECT. SCHEMATIC COMM, MODULE I/O

1

2

3

4

VSM-DWG-MINE1-100-E10-1.DWG

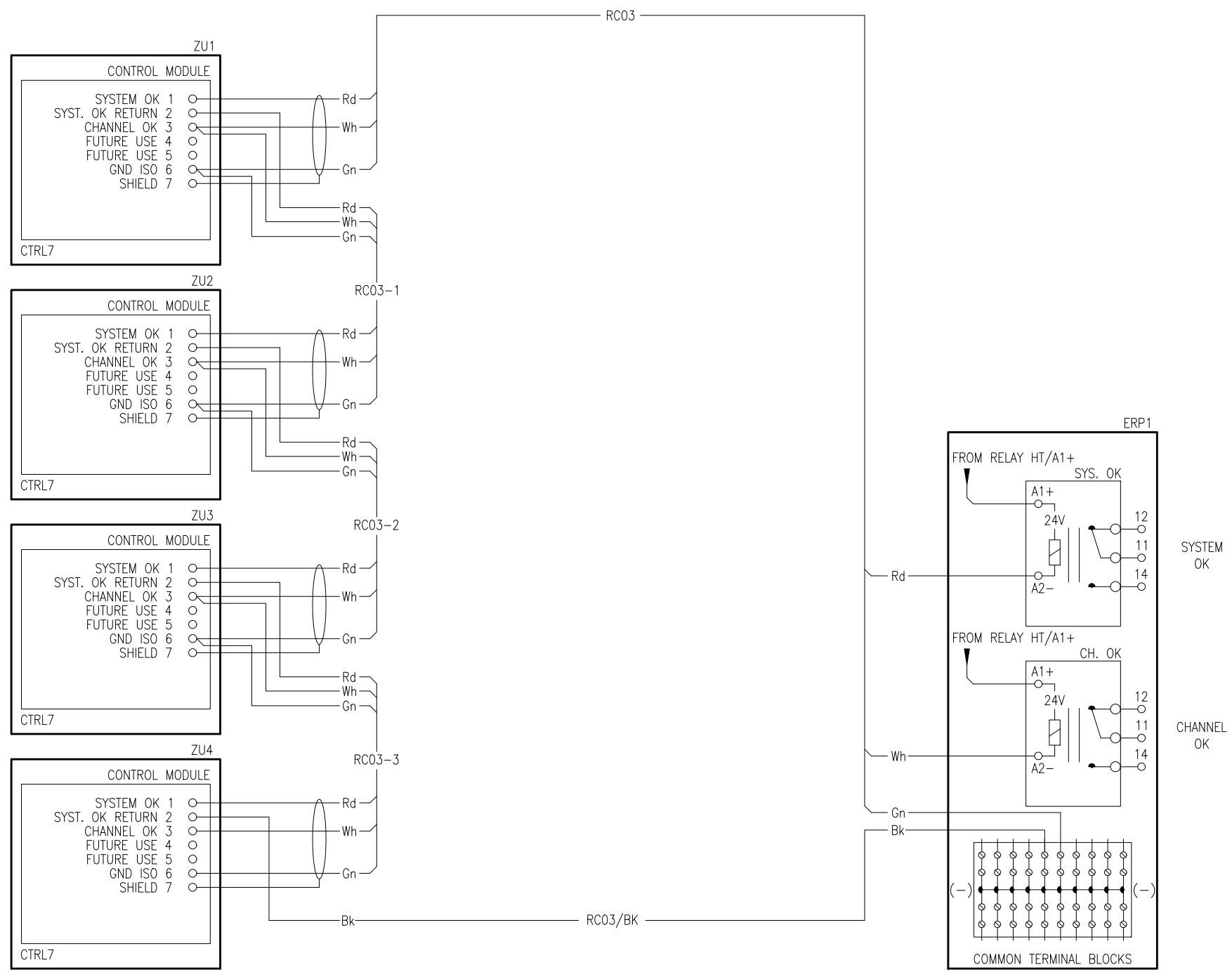

CADREBH2023revB



© Copyright VibroSystM inc.2023
 VibroSystM inc. reserves the right to make changes without prior notice to improve the product.

Section: E ZOOM MONITORING CABINET INTERNAL COMPONENTS & WIRING
 Product number: VSM-CAB-MINE1-100
 Drawing number: VSM-DWG-MINE1-100
 Sheet: E11 Rev. : 1

Title: ZOOM MONITORING SYSTEM FOR PROJECT: YOUR MINING SITE
 ELECT. SCHEMATIC SYS. OK- CH. OK ALARMS

1

2

3

4

A

A

B

B

C

C

D

D

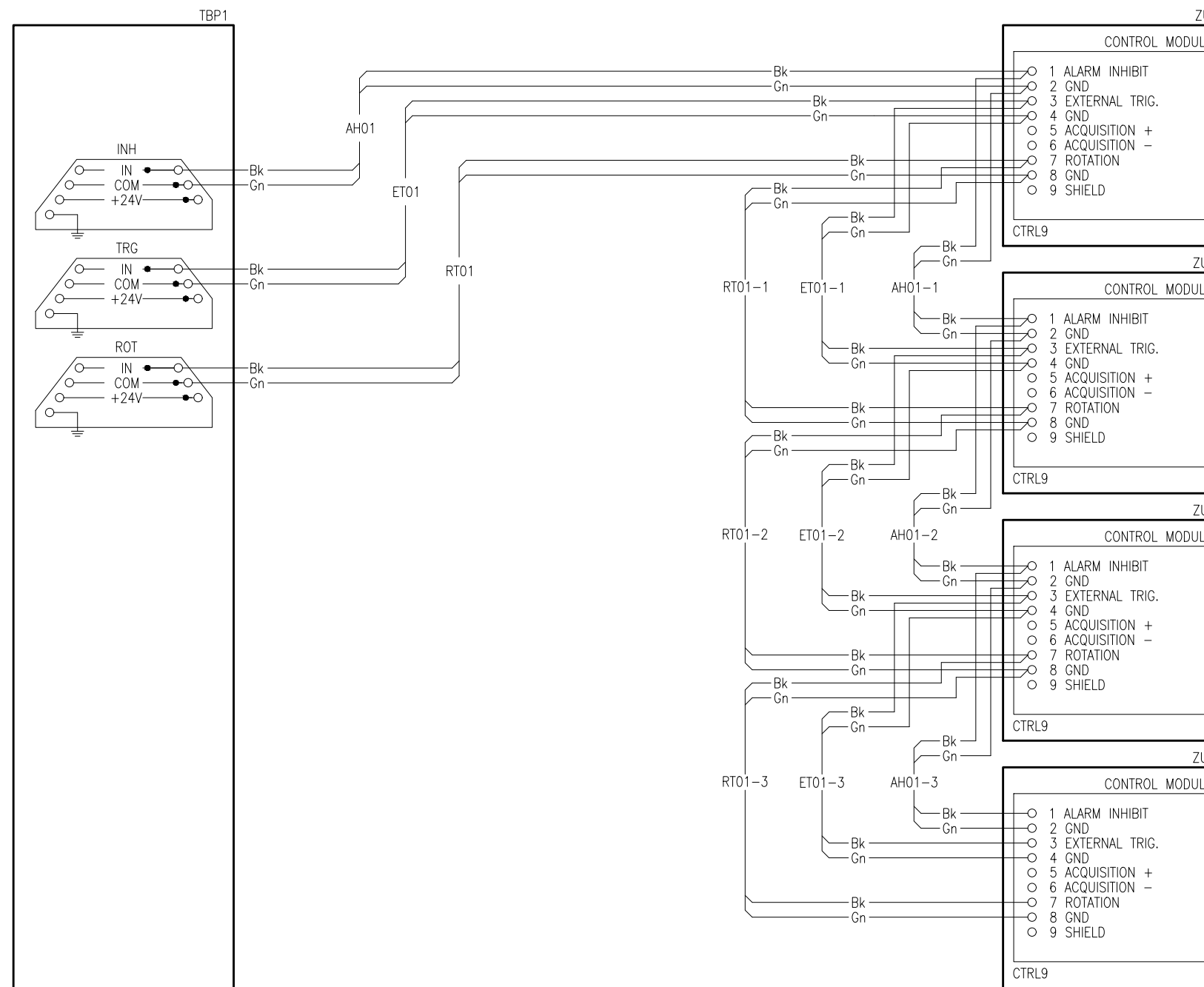

CADREB2023revB



© Copyright VibroSystM inc. 2023
 VibroSystM inc. reserves the right to make changes without prior notice to improve the product.

Section: E ZOOM MONITORING CABINET INTERNAL COMPONENTS & WIRING
 Product number: VSM-CAB-MINE1-100
 Drawing number: VSM-DWG-MINE1-100
 Sheet: E12 Rev.: 1

Title: ZOOM MONITORING SYSTEM FOR PROJECT: YOUR MINING SITE
 ELECT. SCHEMATIC CLIENT PARAMETERS

1

2

3

4

VSM-DWG-MINE1-100-E12-1.DWG

1

2

3

4

A

A

B

B

C

C

D

D

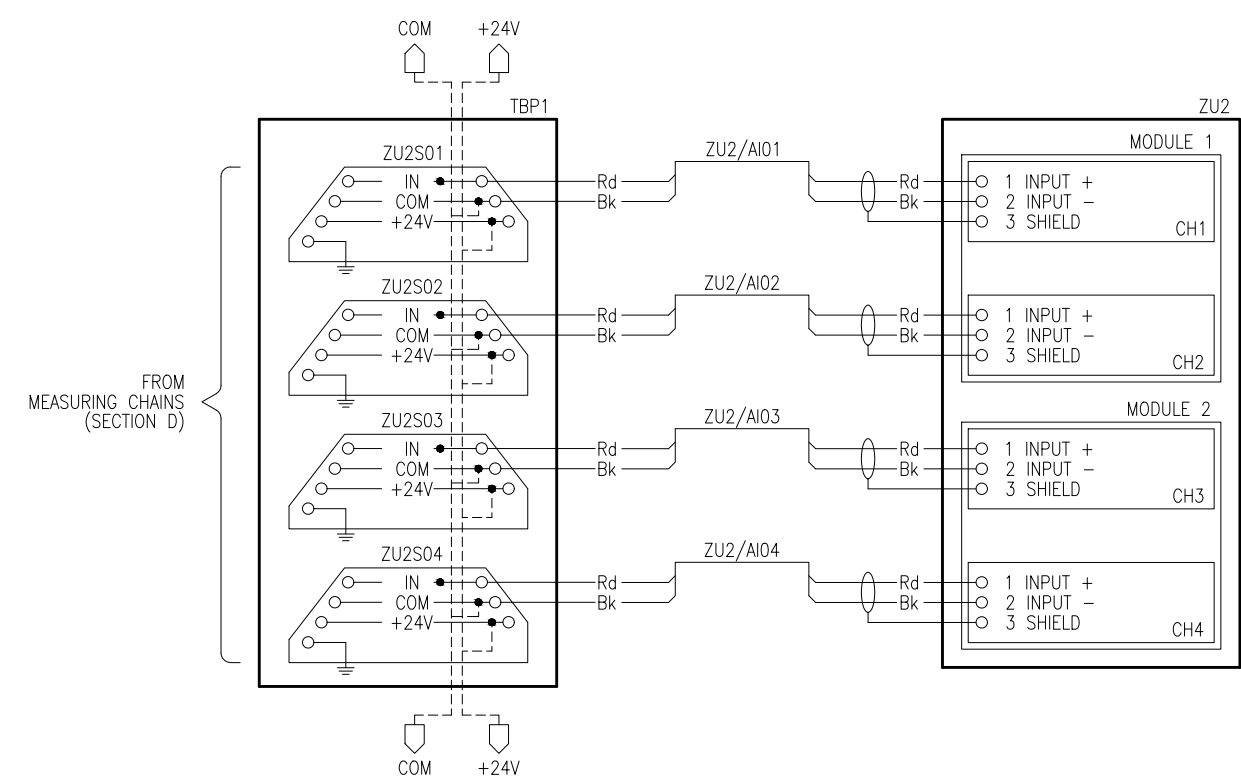
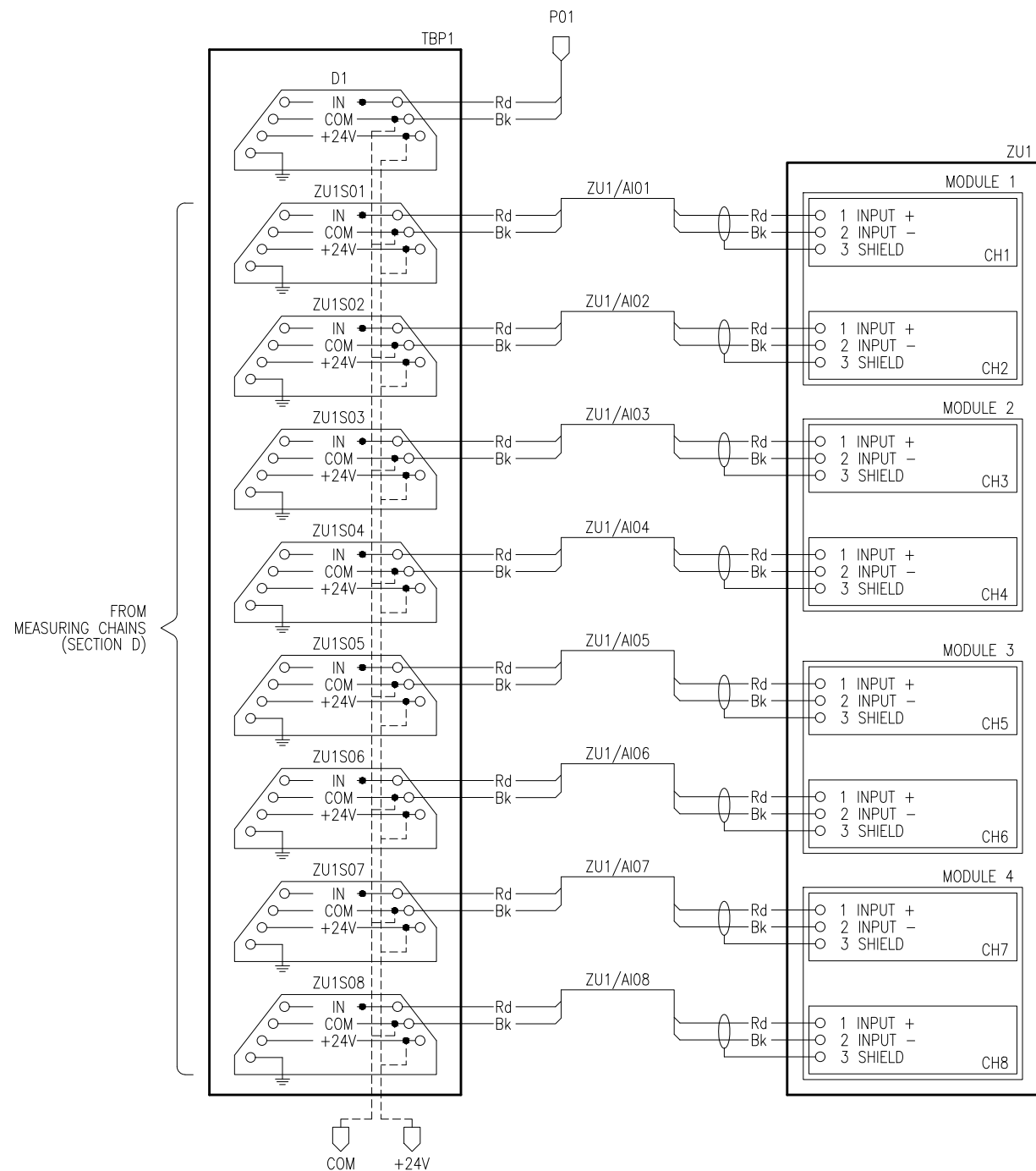

CADREB/2023revB



© Copyright VibroSystM inc.2023
 VibroSystM inc. reserves the right to make changes without prior notice to improve the product.

Section: E ZOOM MONITORING CABINET INTERNAL COMPONENTS & WIRING
 Product number: VSM-CAB-MINE1-100
 Drawing number: VSM-DWG-MINE1-100
 Sheet: E13 Rev. : 1

Title: ZOOM MONITORING SYSTEM FOR PROJECT: YOUR MINING SITE
 ELECT. SCHEMATIC AIR GAP INPUTS

1

2

3

4

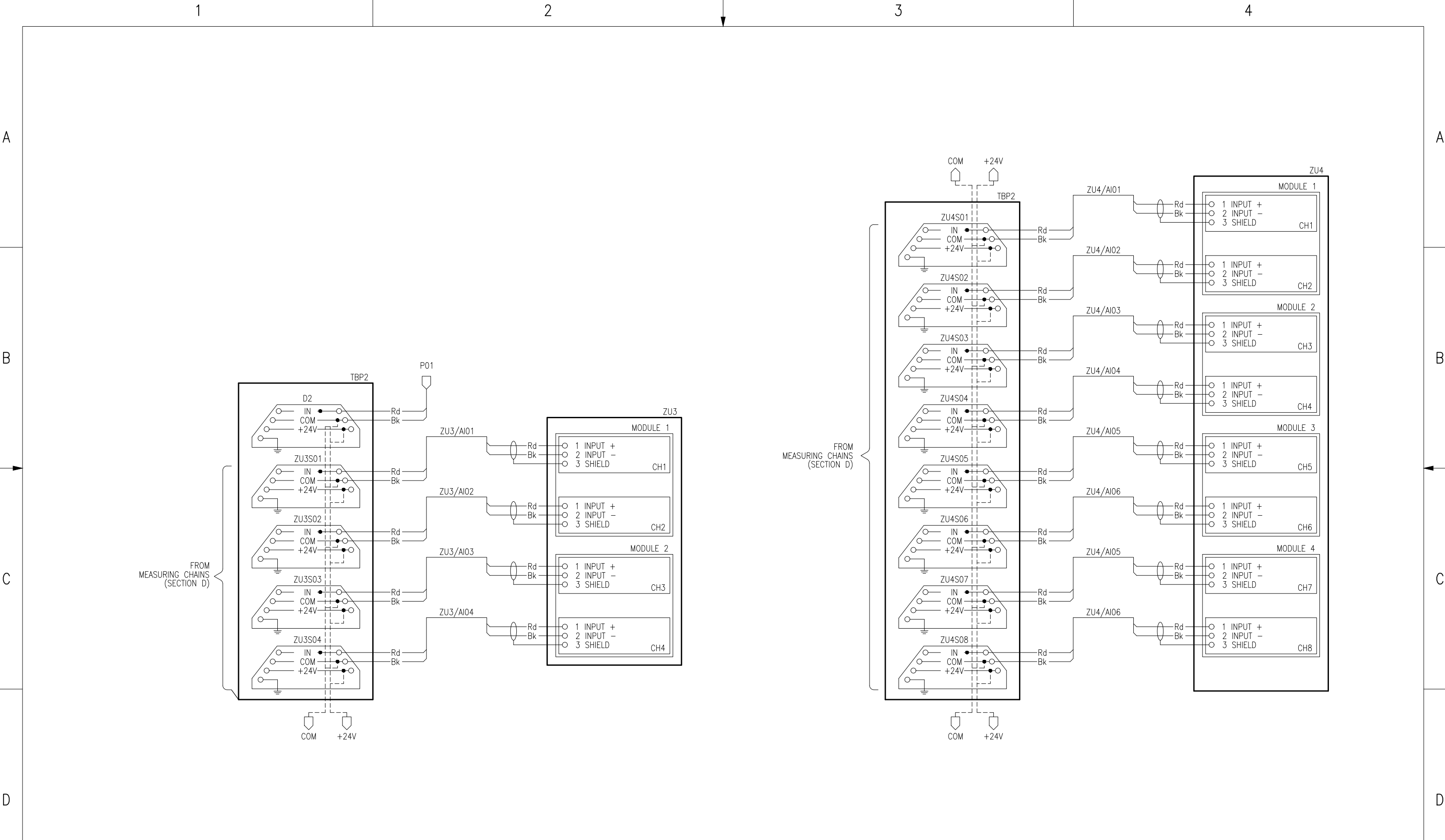

CADREB2023revB



© Copyright VibroSystM inc.2023
 VibroSystM inc. reserves the right to make changes without prior notice to improve the product.

Section: E ZOOM MONITORING CABINET INTERNAL COMPONENTS & WIRING
 Product number: VSM-CAB-MINE1-100
 Drawing number: VSM-DWG-MINE1-100
 Sheet: E14 Rev. : 1

Title: ZOOM MONITORING SYSTEM FOR PROJECT: YOUR MINING SITE
 ELECT. SCHEMATIC AIR GAP INPUTS

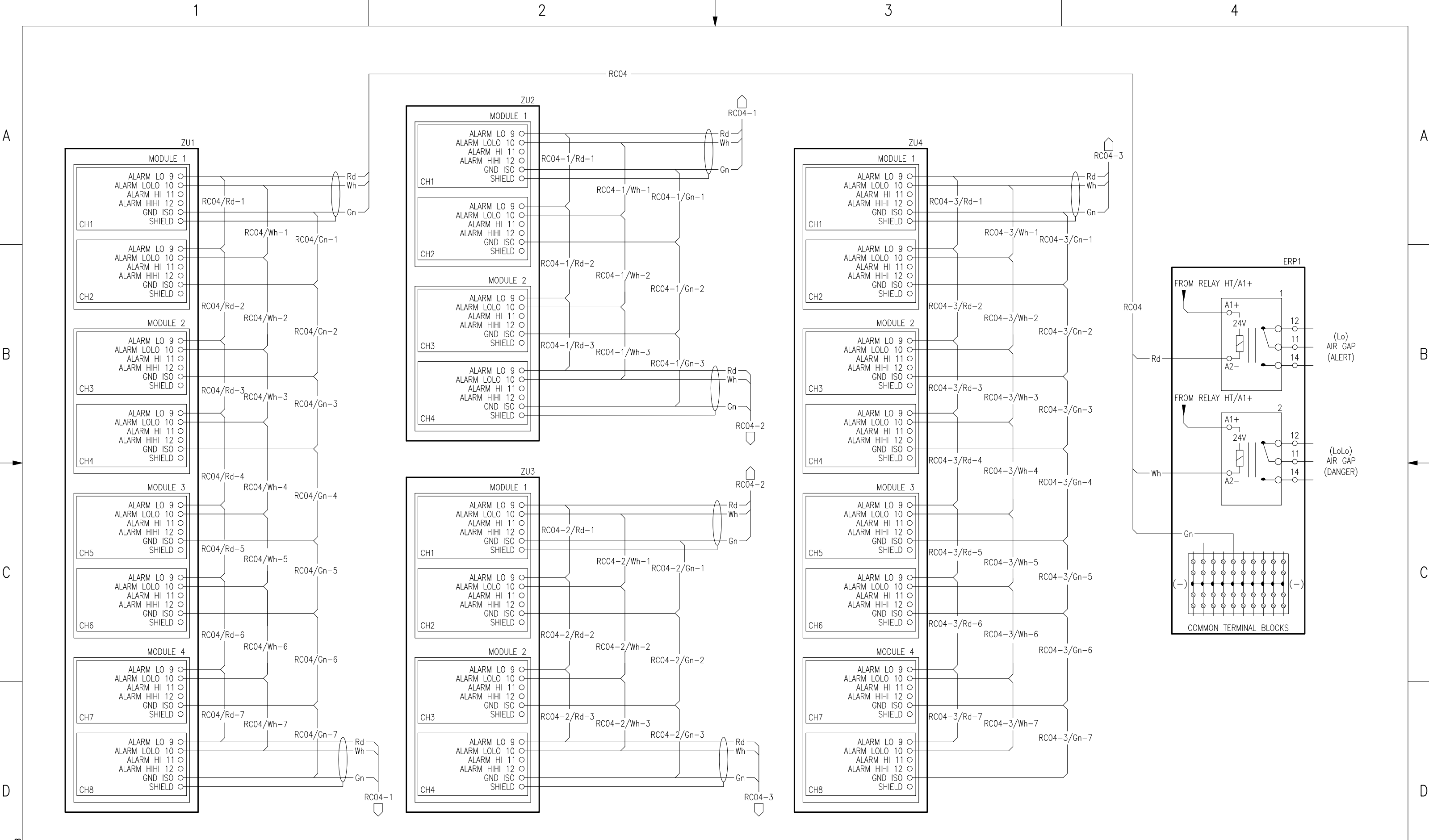

CADREB2023revB



© Copyright VibroSystM inc. 2023
 VibroSystM inc. reserves the right to make changes without prior notice to improve the product.

Section: E ZOOM MONITORING CABINET INTERNAL COMPONENTS & WIRING
 Product number: VSM-CAB-MINE1-100
 Drawing number: VSM-DWG-MINE1-100
 Sheet: E15 Rev. : 1

Title: ZOOM MONITORING SYSTEM FOR PROJECT: YOUR MINING SITE
 ELECT. SCHEMATIC AIR GAP ALARMS

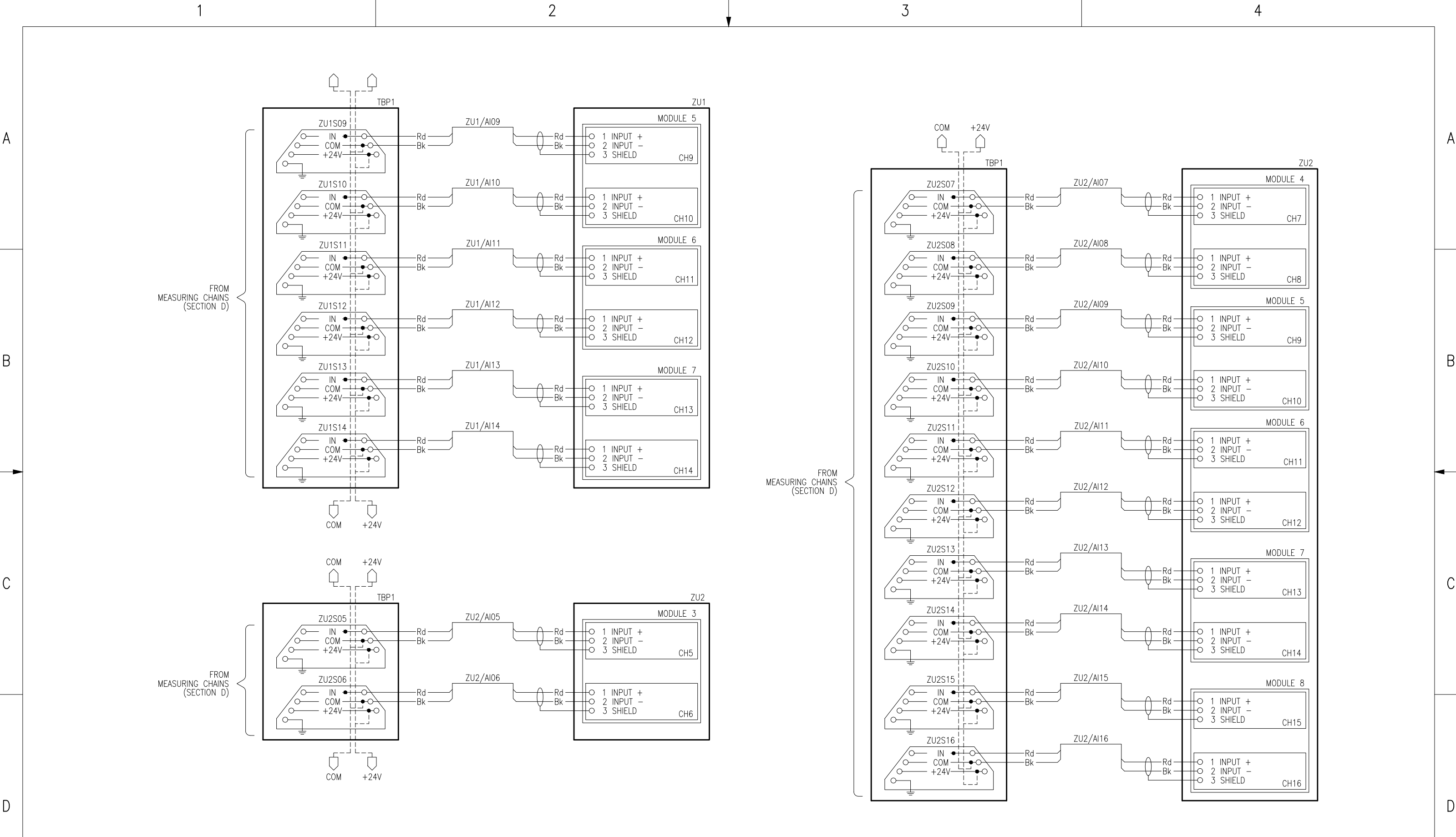

CADREB2023revB



© Copyright VibroSystM inc.2023
 VibroSystM inc. reserves the right to make changes without prior notice to improve the product.

Section: E ZOOM MONITORING CABINET INTERNAL COMPONENTS & WIRING
 Product number: VSM-CAB-MINE1-100
 Drawing number: VSM-DWG-MINE1-100
 Sheet: E16 Rev.: 1

Title: ZOOM MONITORING SYSTEM FOR PROJECT: YOUR MINING SITE
 ELECT. SCHEMATIC END-WINDING VIBRATION ANALOG INPUTS

A

A

B

B

C

C

D

D

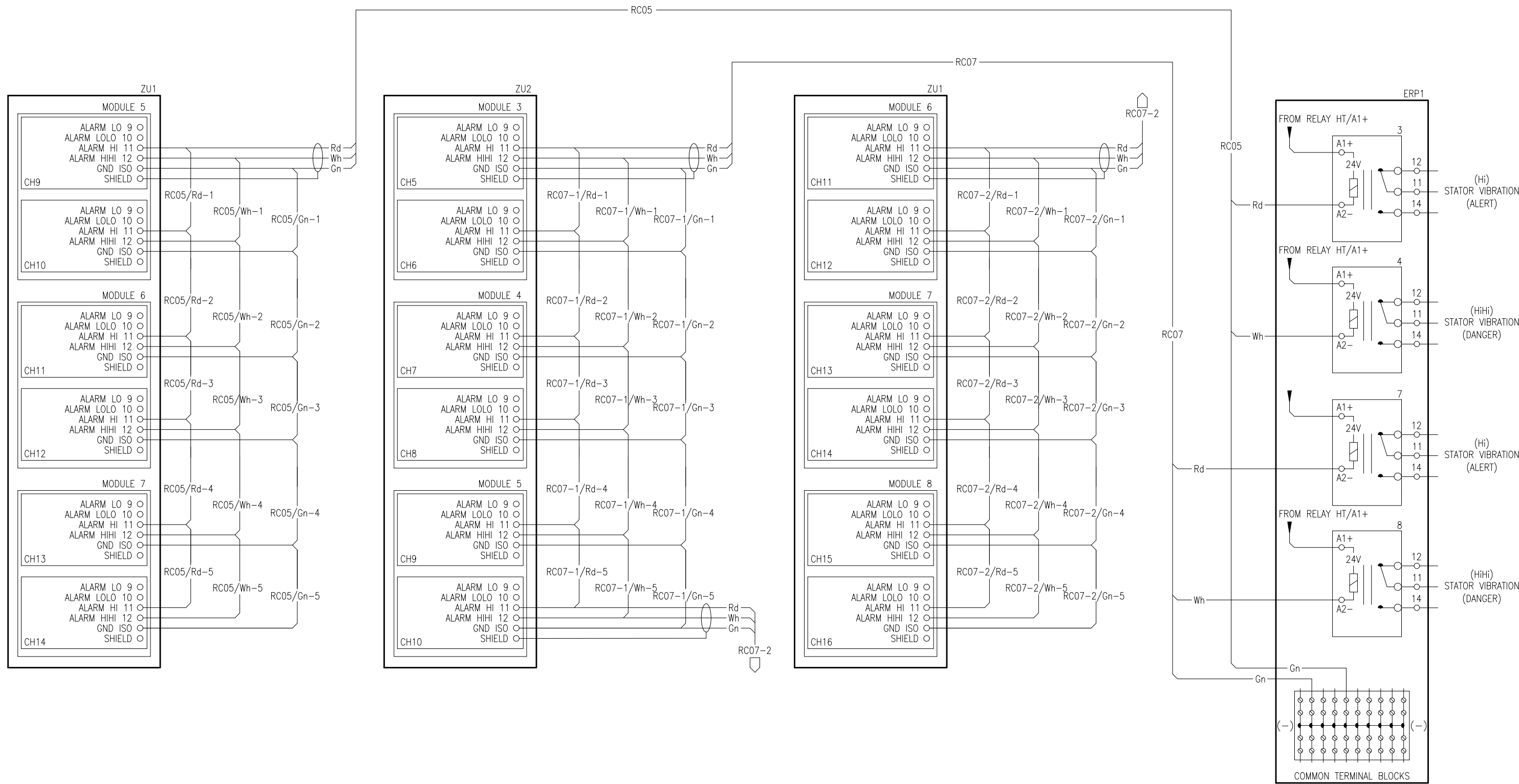

CADREB2023revB



© Copyright VibrosystM inc.2023
 VibrosystM inc. reserves the right to make changes without prior notice to improve the product.

Section: E ZOOM MONITORING CABINET INTERNAL COMPONENTS & WIRING
 Product number: VSM-CAB-MINE1-100
 Drawing number: VSM-DWG-MINE1-100
 Sheet: E17 Rev. : 1

Title: ZOOM MONITORING SYSTEM FOR PROJECT: YOUR MINING SITE
 ELECT. SCHEMATIC END-WINDING ALARMS

A

B

C

D

1

2

3

4

A

B

C

D

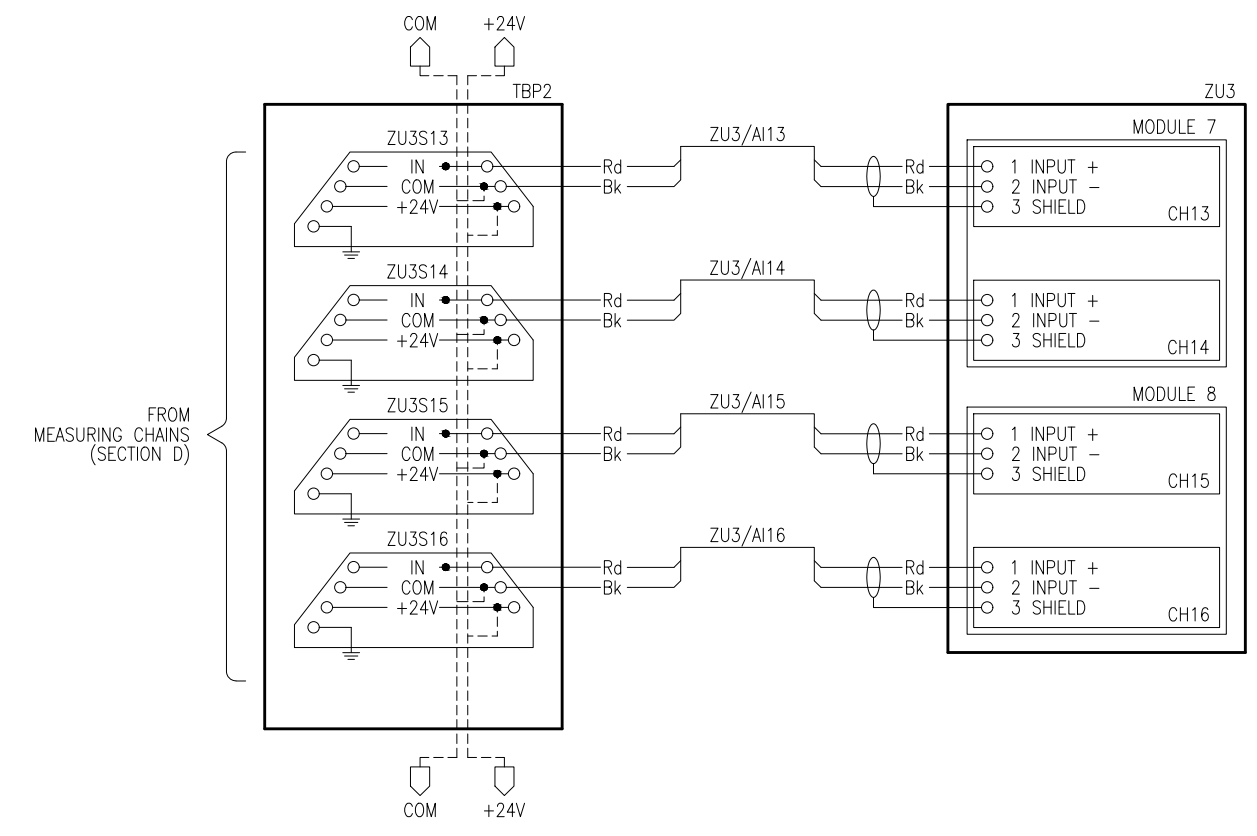
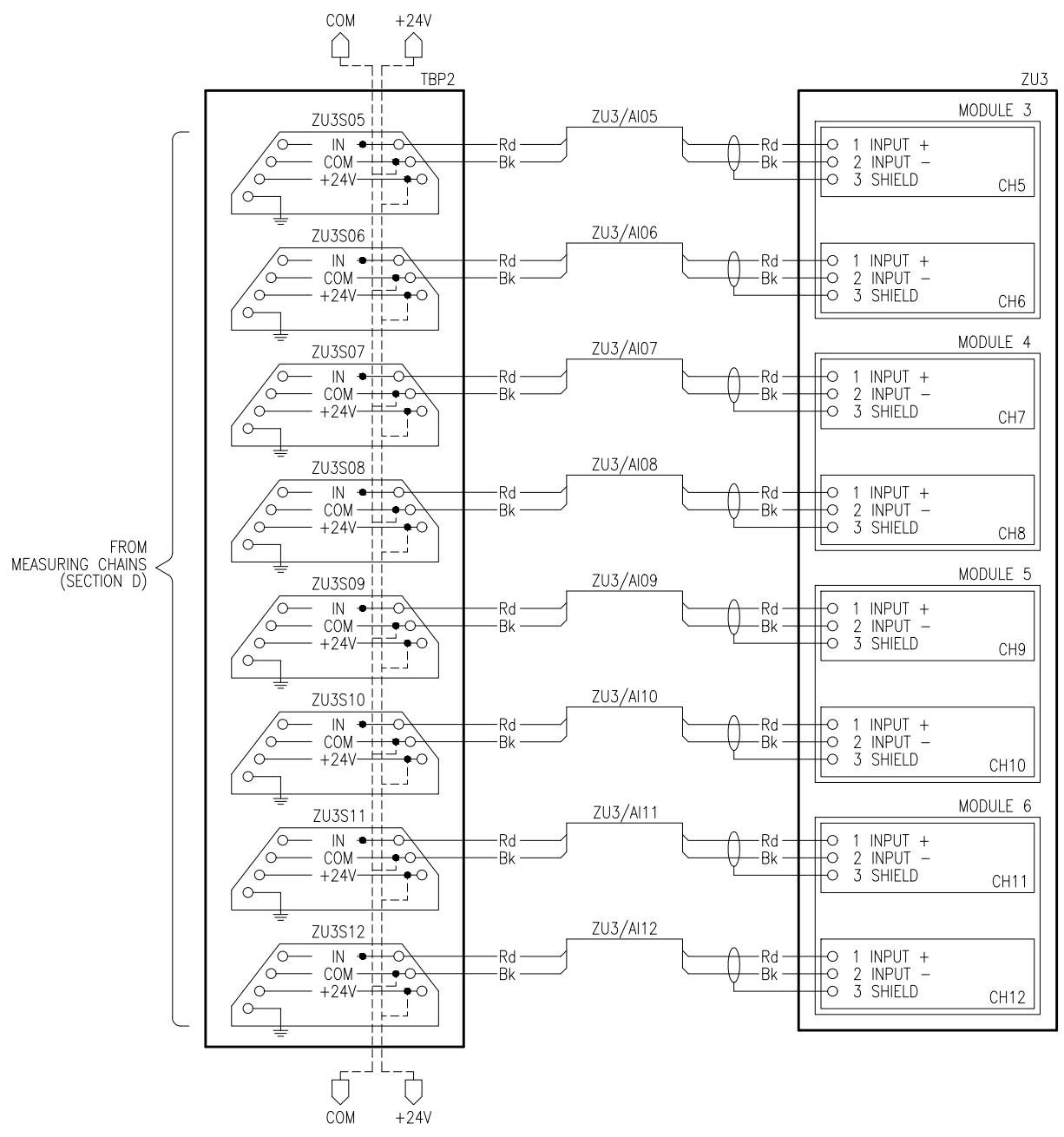

CADREB2023revB



© Copyright VibroSystM inc.2023
 VibroSystM inc. reserves the right to make changes without prior notice to improve the product.

Section: E ZOOM MONITORING CABINET INTERNAL COMPONENTS & WIRING
 Product number: VSM-CAB-MINE1-100
 Drawing number: VSM-DWG-MINE1-100
 Sheet: E18 Rev. : 1

Title: ZOOM MONITORING SYSTEM FOR PROJECT: YOUR MINING SITE
 ELECT. SCHEMATIC STATOR CORE VIBRATION ANALOG INPUTS

1

2

3

4

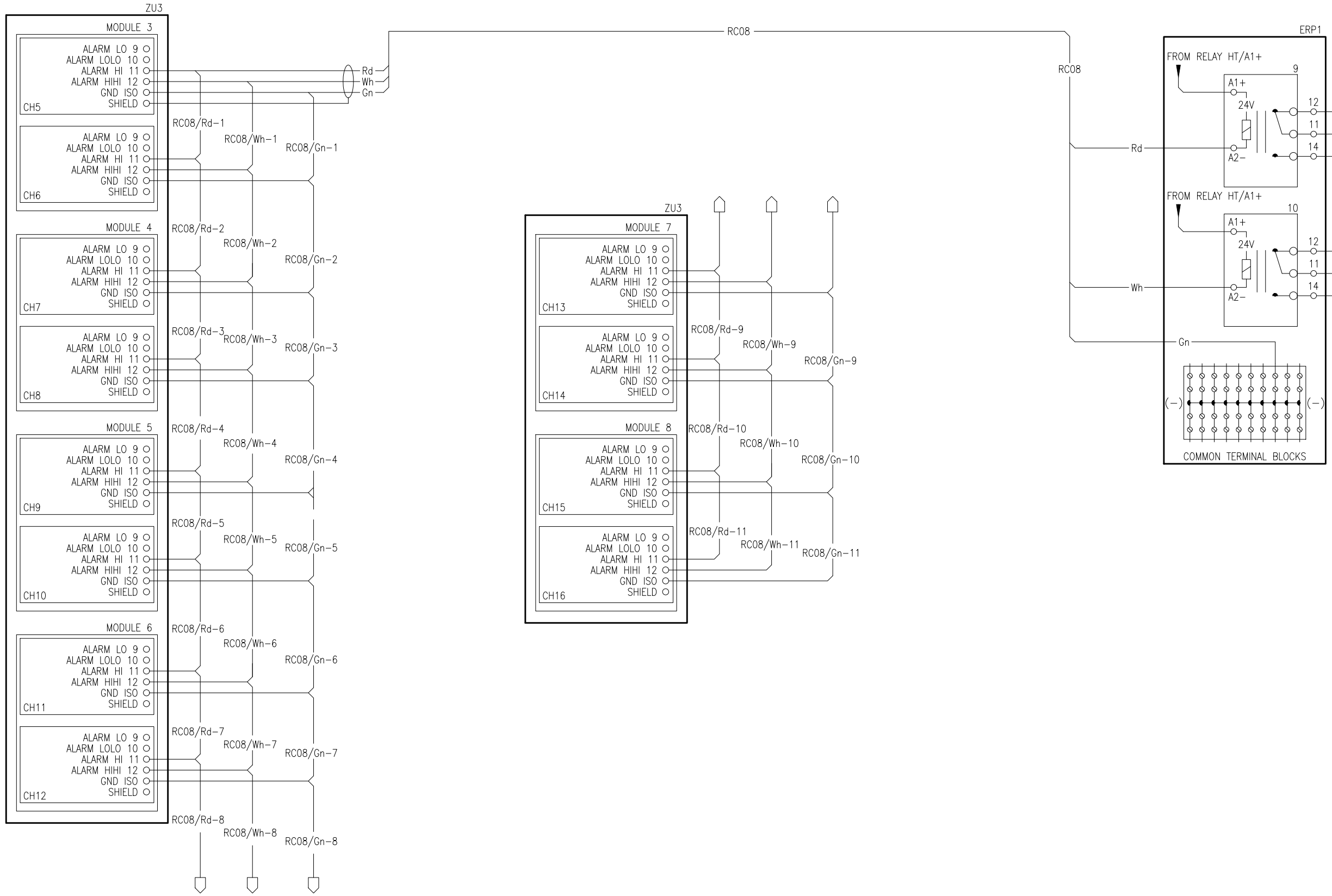

A

A

B

B

C

C

D

D

CADREB2023revB



© Copyright VibroSystM inc.2023
 VibroSystM inc. reserves the right to make changes without prior notice to improve the product.

Section: E ZOOM MONITORING CABINET INTERNAL COMPONENTS & WIRING
 Product number: VSM-CAB-MINE1-100
 Drawing number: VSM-DWG-MINE1-100
 Sheet: E19 Rev. : 1

Title: ZOOM MONITORING SYSTEM FOR PROJECT: YOUR MINING SITE
 ELECT. SCHEMATIC STATOR CORE ALARMS

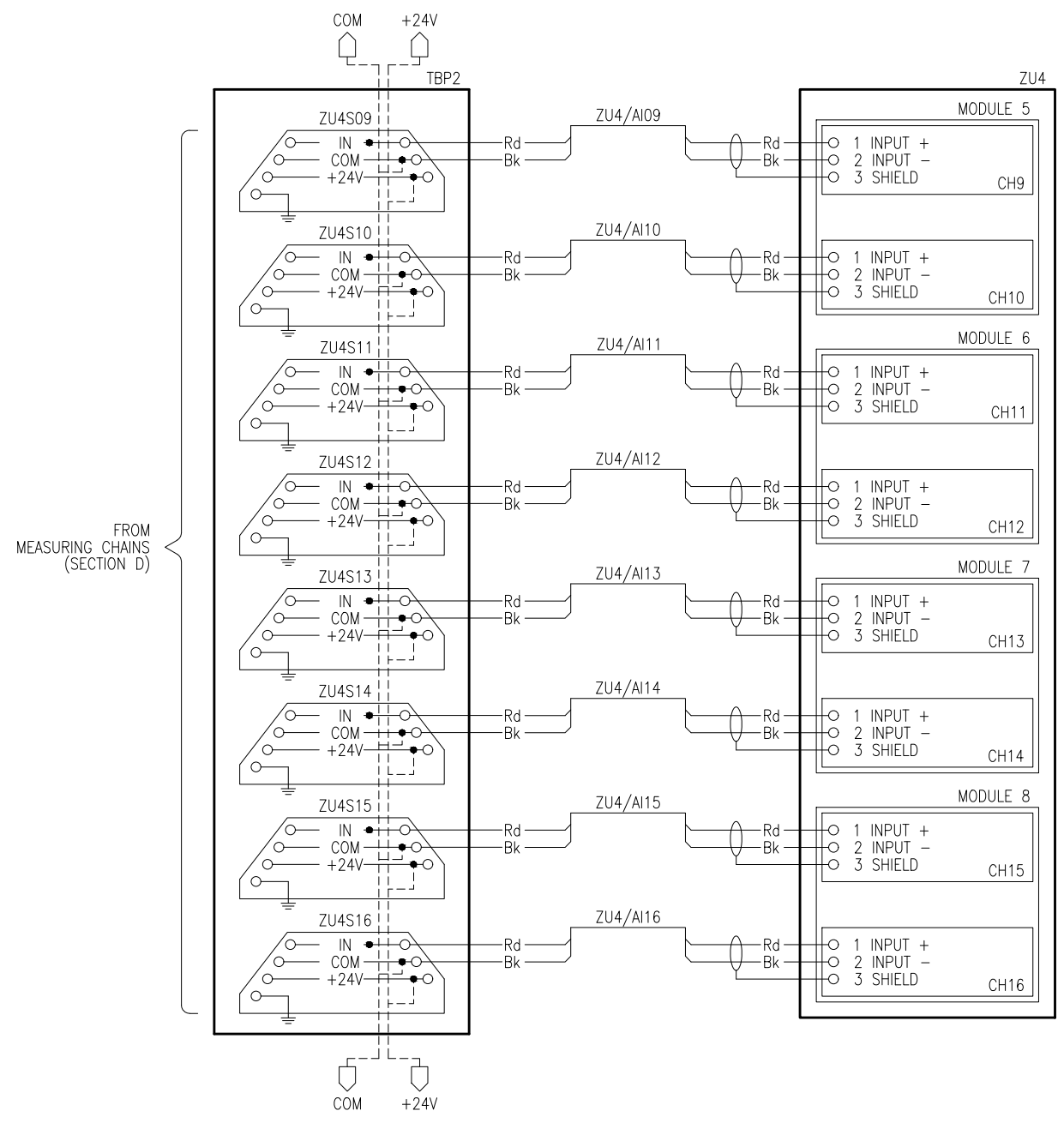

CADREB2023revB



© Copyright VibroSystM inc.2023
 VibroSystM inc. reserves the right to make changes without prior notice to improve the product.

Section: E ZOOM MONITORING CABINET INTERNAL COMPONENTS & WIRING
 Product number: VSM-CAB-MINE1-100
 Drawing number: VSM-DWG-MINE1-100
 Sheet: E20 Rev.: 1

Title: ZOOM MONITORING SYSTEM FOR PROJECT: YOUR MINING SITE
 ELECT. SCHEMATIC STATOR FRAME & SOLE PLATE VIB. ANALOG INPUTS

1

2

3

4

A

A

B

B

C

C

D

D

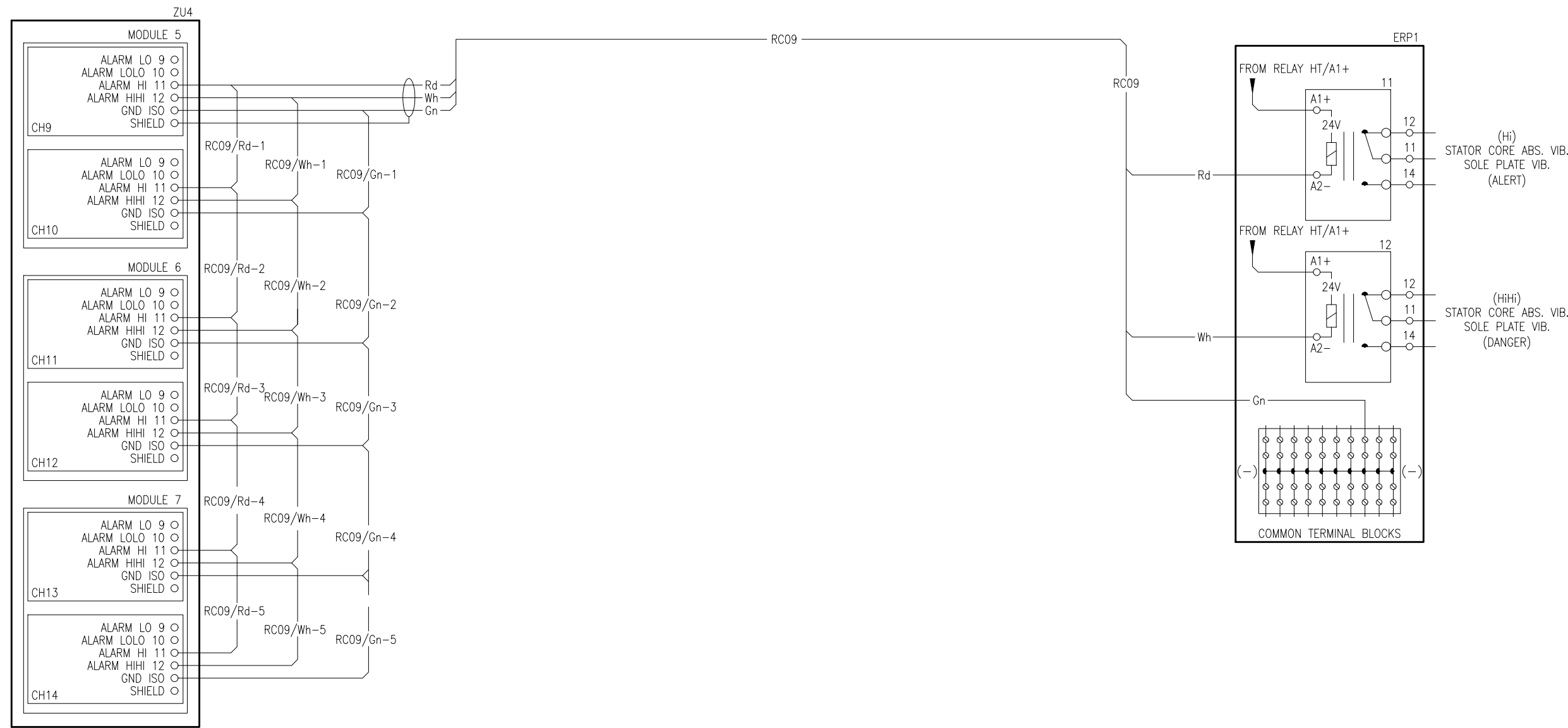

CADREB2023revB



© Copyright VibroSystM inc.2023
 VibroSystM inc. reserves the right to make changes without prior notice to improve the product.

Section: E ZOOM MONITORING CABINET INTERNAL COMPONENTS & WIRING
 Product number: VSM-CAB-MINE1-100
 Drawing number: VSM-DWG-MINE1-100
 Sheet: E21 Rev. : 1

Title: ZOOM MONITORING SYSTEM FOR PROJECT: YOUR MINING SITE
 ELECT. SCHEMATIC STATOR FRAME & SOLE PLATE ALARMS

1

2

3

4

1

2

3

4

A

A

B

B

C

C

D

D

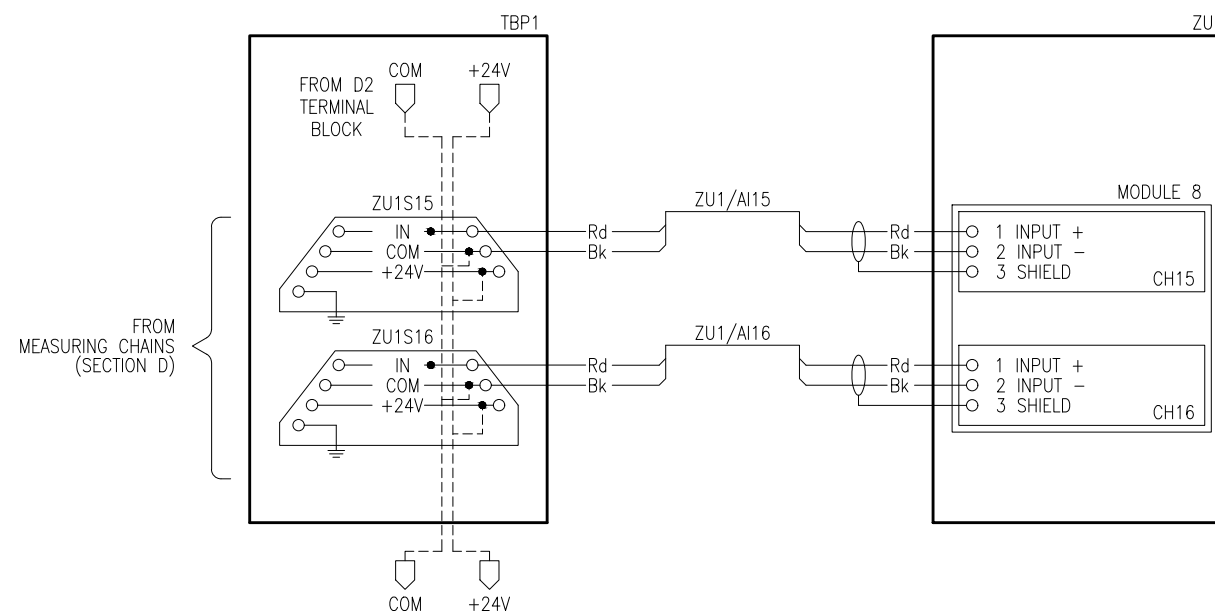

CADREB2023revB



© Copyright VibroSystM inc.2023
 VibroSystM inc. reserves the right to make changes without prior notice to improve the product.

Section: E ZOOM MONITORING CABINET INTERNAL COMPONENTS & WIRING
 Product number: VSM-CAB-MINE1-100
 Drawing number: VSM-DWG-MINE1-100
 Sheet: E22 Rev. : 1

Title: ZOOM MONITORING SYSTEM FOR PROJECT: YOUR MINING SITE
 ELECT. SCHEMATIC ROTOR TEMPERATURE ANALOG INPUTS

1

2

3

4

VSM-DWG-MINE1-100-E22-1.DWG

1

2

3

4

A

A

B

B

C

C

D

D

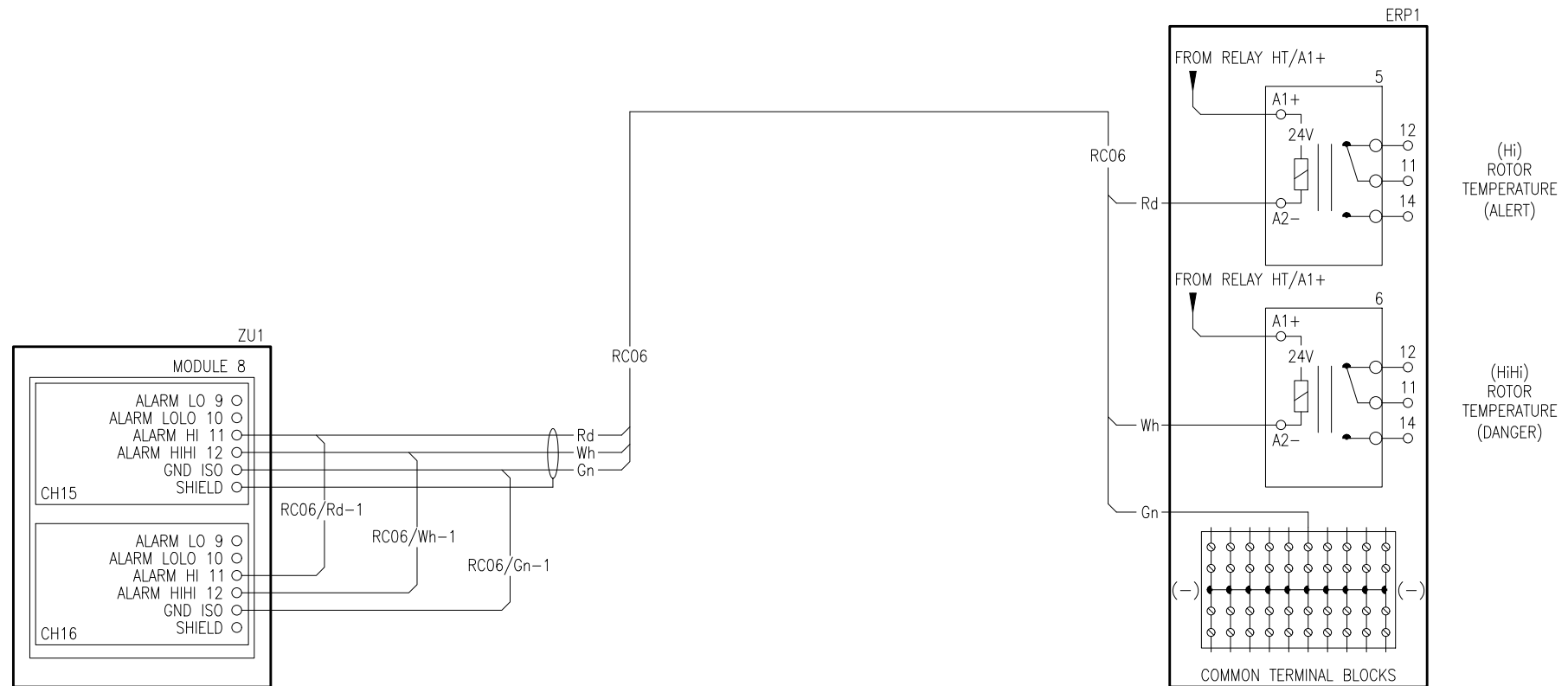

CADREB2023revB



© Copyright VibroSystM inc. 2023
 VibroSystM inc. reserves the right to make changes without prior notice to improve the product.

Section: E ZOOM MONITORING CABINET INTERNAL COMPONENTS & WIRING
 Product number: VSM-CAB-MINE1-100
 Drawing number: VSM-DWG-MINE1-100
 Sheet: E23 Rev.: 1

Title: ZOOM MONITORING SYSTEM FOR PROJECT: YOUR MINING SITE
 ELECT. SCHEMATIC ROTOR TEMPERATURE ALARMS

1

2

3

4

1

2

3

4

VSM-WME48-F2L2T45
(E1)

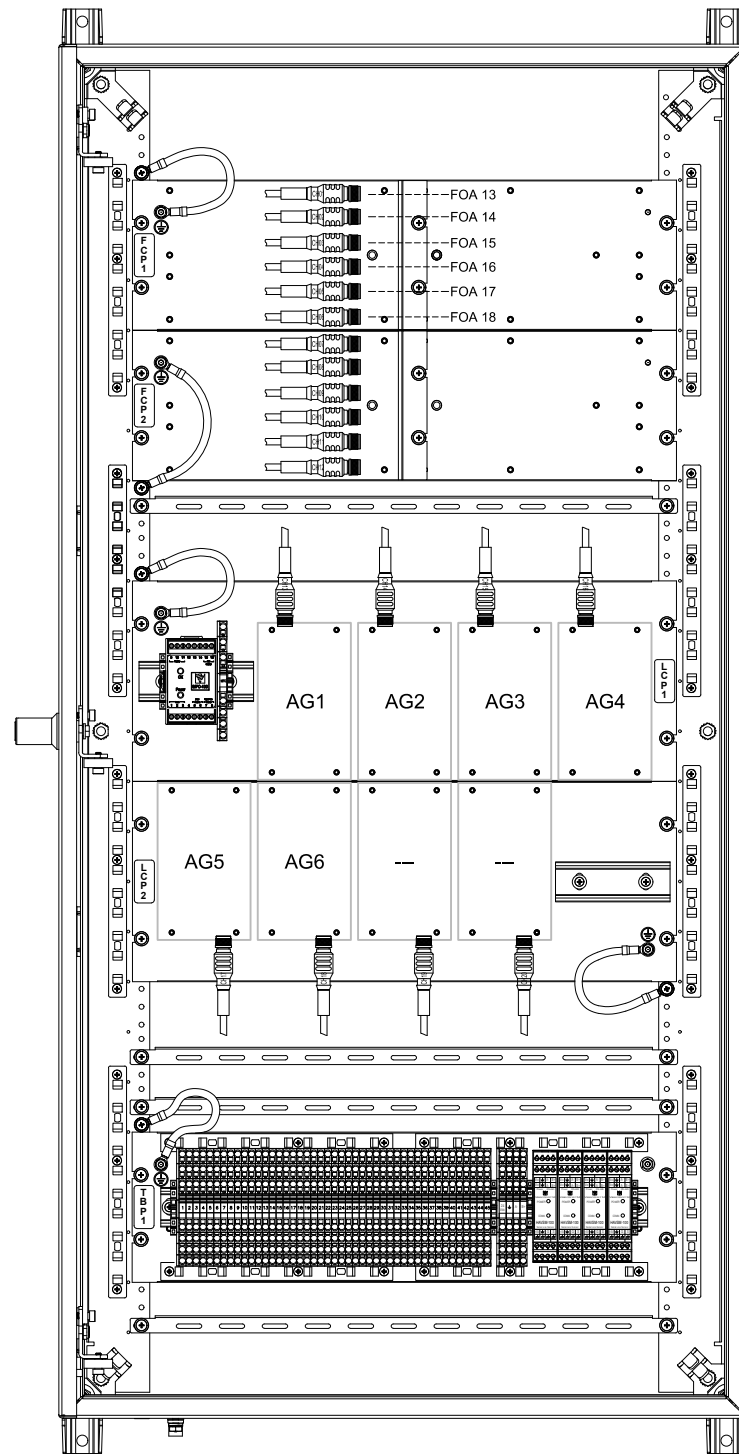

JUNCTION BOX CONNECTIONS DETAILS						
WALLMOUNT ENCLOSURE	VSM TAG	SIZE (HxWxD) IN.	INPUT SENSOR	CABLE INPUT TAG	TERMINAL BLOCK #	CABLE OUTPUT TAG
VSM-WME48-F2L2T45	E1	48x24x8	FOA13	FOA13/E1-1	1	E1-1/E6-7
			FOA14	FOA14/E1-2	2	E1-2/E6-8
			FOA15	FOA15/E1-3	3	E1-3/E6-9
			FOA16	FOA16/E1-4	4	E1-4/E6-10
			FOA17	FOA17/E1-5	5	E1-5/E6-11
			FOA18	FOA18/E1-6	6	E1-6/E6-12
			TWR1	TWR1/E1-7	7	E1-7/E6-38
			AG1	AG1/E1-13	13	E1-13/E6-1
			AG2	AG2/E1-14	14	E1-14/E6-2
			AG3	AG3/E1-15	15	E1-15/E6-3
			AG4	AG4/E1-16	16	E1-16/E6-4
			AG5	AG5/E1-17	17	E1-17/E6-5
			AG6	AG6/E1-18	18	E1-18/E6-6
			MFP1	MFP1/E1-MFC	MFC	E1-MFC/E6-27
			SCT1-45	SCT1-45/E1-H1	Vdc ⊥ A- B+	E1-H1PWR/E6-29 E1-H1RS/E6-30
			SCT1-46-90	SCT46-90/E1-H2	Vdc ⊥ A- B+	E1-H1PWR/E6-29 E1-H1RS/E6-30
			SCT1-181-225	SCT181-225/E1-H5	Vdc ⊥ A- B+	E1-H1PWR/E6-29 E1-H1RS/E6-30
			SCT1-226-270	SCT226-270/E1-H6	Vdc ⊥ A- B+	E1-H1PWR/E6-29 E1-H1RS/E6-30

A

A

B

B

C

C

D

D

CADREB2023revB



© Copyright VibroSystem inc. 2023
VibroSystem inc. reserves the right to make changes without prior notice to improve the product.

Section: F JUNCTION BOXES (WME) INTERNAL COMPONENTS & WIRING
Product number: VSM-CAB-MINE1-100
Drawing number: VSM-DWG-MINE1-100
Sheet: F1 Rev. : 1

Title: ZOOM MONITORING SYSTEM FOR PROJECT: YOUR MINING SITE
JUNCTION BOXES DETAILS

1

2

3

4

1

2

3

4

VSM-WME48-F2L2T45
(E4)

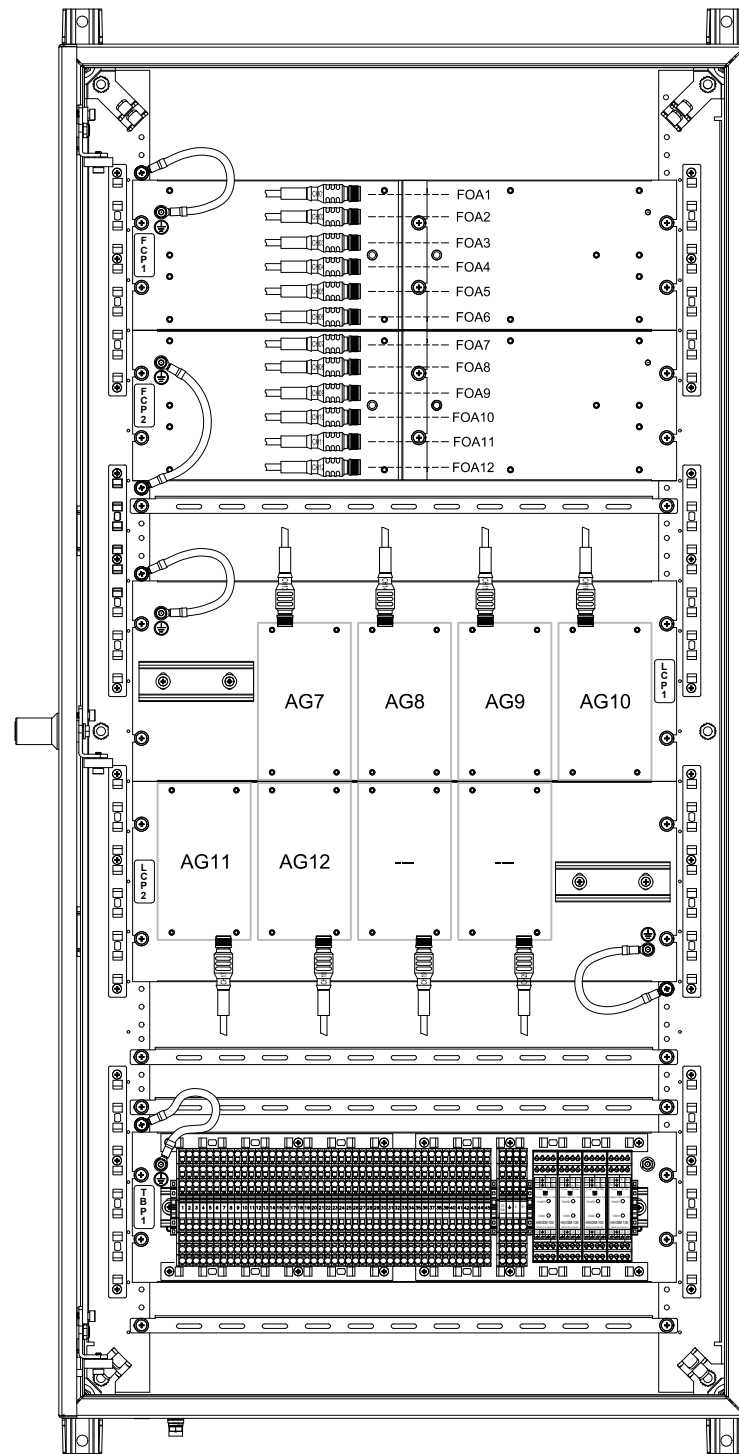

JUNCTION BOX CONNECTIONS DETAILS						
WALLMOUNT ENCLOSURE	VSM TAG	SIZE (HxWxD) IN.	INPUT SENSOR	CABLE INPUT TAG	TERMINAL BLOCK #	CABLE OUTPUT TAG
VSM-WME48-F2L2T45	E4	48x24x8	FOA1	FOA1/E4-1	1	E4-1/E7-8
			FOA2	FOA2/E4-2	2	E4-2/E7-9
			FOA3	FOA3/E4-3	3	E4-3/E7-10
			FOA4	FOA4/E4-4	4	E4-4/E7-11
			FOA5	FOA5/E4-5	5	E4-5/E7-12
			FOA6	FOA6/E4-6	6	E4-6/E7-13
			FOA7	FOA7/E4-7	7	E4-7/E7-14
			FOA8	FOA8/E4-8	8	E4-8/E7-15
			FOA9	FOA9/E4-9	9	E4-9/E7-16
			FOA10	FOA10/E4-10	10	E4-10/E7-17
			FOA11	FOA11/E4-11	11	E4-11/E7-18
			FOA12	FOA12/E4-12	12	E4-12/E7-19
			AG7	AG7/E4-13	13	E4-13/E7-1
			AG8	AG8/E4-14	14	E4-14/E7-2
			AG9	AG9/E4-15	15	E4-15/E7-3
			AG10	AG10/E4-16	16	E4-16/E7-4
			AG11	AG11/E4-17	17	E4-17/E7-5
			AG12	AG12/E4-18	18	E4-18/E7-6

SCT91-135	SCT91-135/E4-H3	Vdc	E4-H3PWR/E7-29
		⏏	
		A-	E4-H3RS/E7-30
SCT136-180	SCT136-180/E4-H4	Vdc	E4-H3PWR/E7-29
		⏏	
		A-	E4-H3RS/E7-30
SCT271-315	SCT271-315/E4-H7	Vdc	E4-H3PWR/E7-29
		⏏	
		A-	E4-H3RS/E7-30
SCT316-360	SCT316-360/E4-H8	Vdc	E4-H3PWR/E7-29
		⏏	
		A-	E4-H3RS/E7-30

A

A

B

B

C

C

D

D

CADREBH2023revB



© Copyright VibroSystem inc. 2023
VibroSystem inc. reserves the right to make changes without prior notice to improve the product.

Section: F JUNCTION BOXES (WME) INTERNAL COMPONENTS & WIRING
Product number: VSM-CAB-MINE1-100
Drawing number: VSM-DWG-MINE1-100
Sheet: F2 Rev.: 1

Title: ZOOM MONITORING SYSTEM FOR PROJECT: YOUR MINING SITE
JUNCTION BOXES DETAILS

1

2

3

4

VSM-DWG-MINE1-100-F2-1.DWG

1

2

3

4

JUNCTION BOX CONNECTIONS DETAILS						
WALLMOUNT ENCLOSURE	VSM TAG	SIZE (HxWxD) IN.	INPUT SENSOR	CABLE INPUT TAG	TERMINAL BLOCK #	CABLE OUTPUT TAG
VSM-WME36-L2T18	E2	36x24x8	AG13	AG13/E2-1	1	E2-1/E6-31
			AG14	AG14/E2-2	2	E2-2/E6-32
			AG15	AG15/E2-3	3	E2-3/E6-33
			AG16	AG16/E2-4	4	E2-4/E6-34
			AG17	AG17/E2-5	5	E2-5/E6-35
			AG18	AG18/E2-6	6	E2-6/E6-36
			TWR2	TWR2/E2-7	7	E2-7/E6-39

VSM-WMF36-L2T18
(E2)

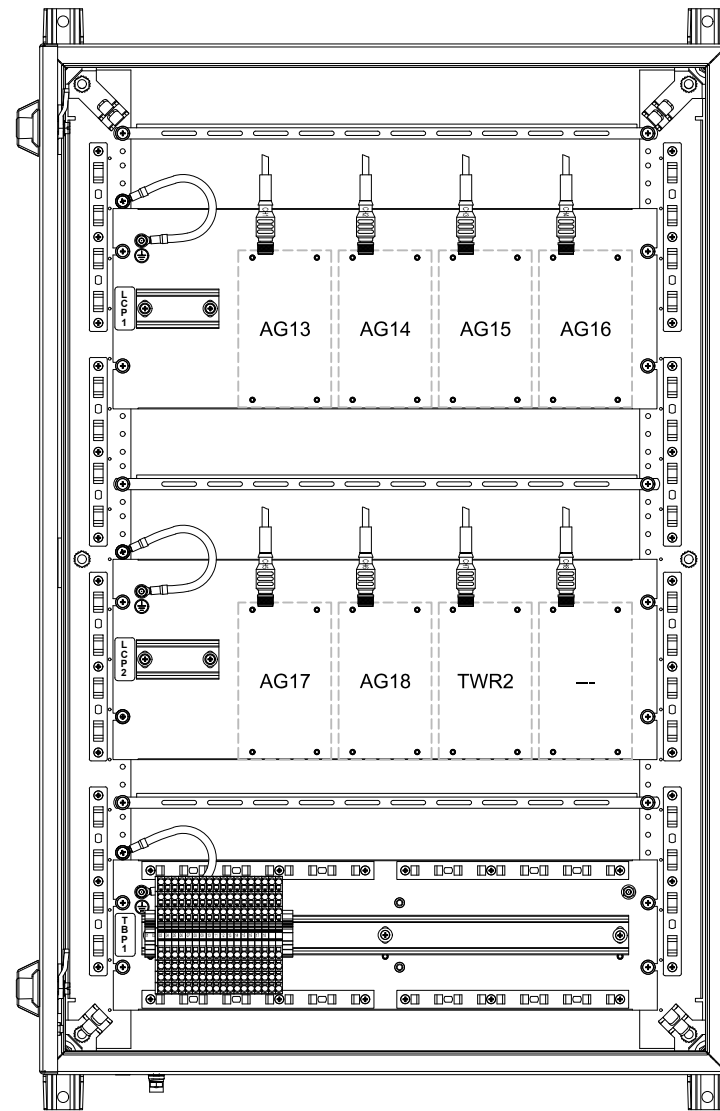

A

A

B

B

C

C

D

D

CADREB2023revB



© Copyright VibroSystM inc.2023
VibroSystM inc. reserves the right to make changes without prior notice to improve the product.

Section: F JUNCTION BOXES (WME) INTERNAL COMPONENTS & WIRING
Product number: VSM-CAB-MINE1-100
Drawing number: VSM-DWG-MINE1-100
Sheet: F3 Rev. : 1

Title: ZOOM MONITORING SYSTEM FOR PROJECT: YOUR MINING SITE
JUNCTION BOXES DETAILS

1

2

3

4

VSM-DWG-MINE1-100-F3-1.DWG

1

2

3

4

JUNCTION BOX CONNECTIONS DETAILS						
WALLMOUNT ENCLOSURE	VSM TAG	SIZE (HxWxD) IN.	INPUT SENSOR	CABLE INPUT TAG	TERMINAL BLOCK #	CABLE OUTPUT TAG
VSM-WME36-L2T18	E3	36x24x8	AG19	AG19/E3-1	1	E3-1/E7-30
			AG20	AG20/E3-2	2	E3-2/E7-31
			AG21	AG21/E3-3	3	E3-3/E7-32
			AG22	AG22/E3-4	4	E3-4/E7-33
			AG23	AG23/E3-5	5	E3-5/E7-34
			AG24	AG24/E3-6	6	E3-6/E7-35

VSM-WME36-L2T18
(E3)

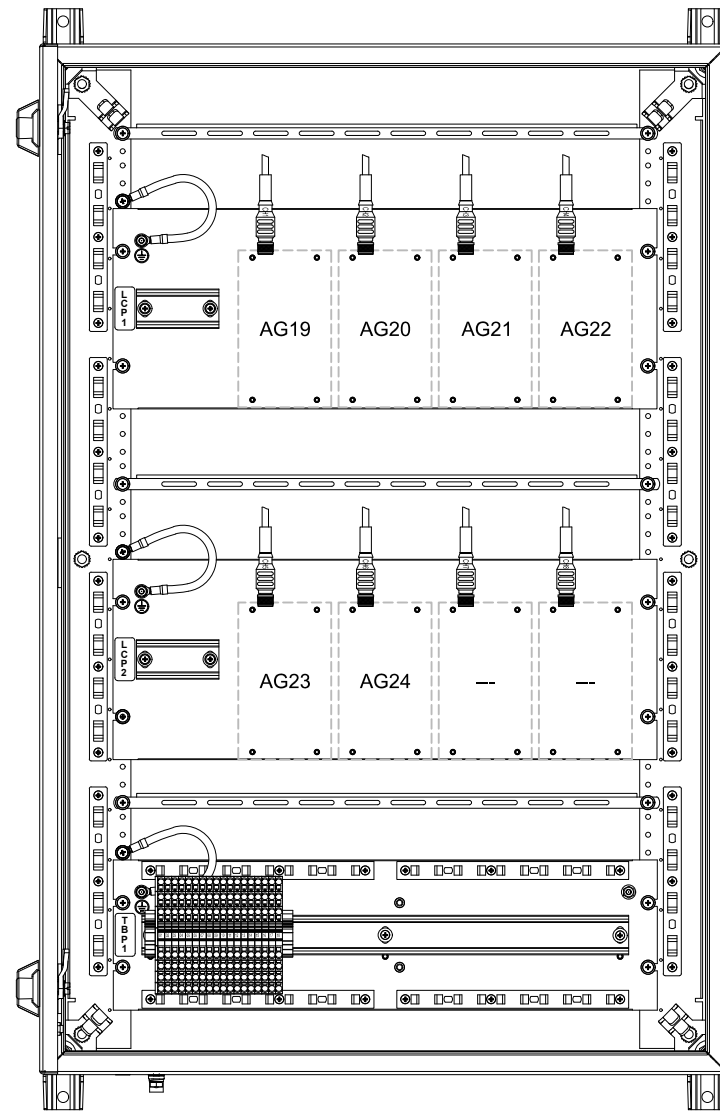

A

A

B

B

C

C

D

D

CADREB2023revB



© Copyright VibroSystM inc.2023
VibroSystM inc. reserves the right to make changes without prior notice to improve the product.

Section: F JUNCTION BOXES (WME) INTERNAL COMPONENTS & WIRING
Product number: VSM-CAB-MINE1-100
Drawing number: VSM-DWG-MINE1-100
Sheet: F4 Rev. : 1

Title: ZOOM MONITORING SYSTEM FOR PROJECT: YOUR MINING SITE
JUNCTION BOXES DETAILS

1

2

3

4

1

2

3

4

VSM-WME24-T66
(E6)

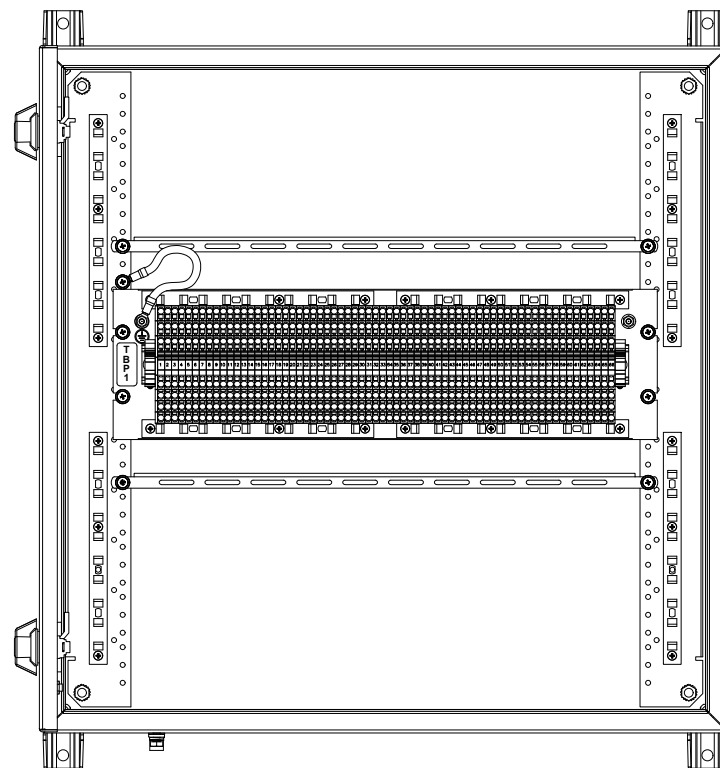

JUNCTION BOX CONNECTIONS DETAILS						
WALLMOUNT ENCLOSURE	VSM TAG	SIZE (HxWxD) IN.	INPUT SENSOR	CABLE INPUT TAG	TERMINAL BLOCK #	CABLE OUTPUT TAG
VSM-WME24-T66	E6	24x24x8	AG1	E1-13/E6-1	1	E6-1/C1-ZU1S01
			AG2	E1-14/E6-2	2	E6-2/C1-ZU1S02
			AG3	E1-15/E6-3	3	E6-3/C1-ZU2S03
			AG4	E1-16/E6-4	4	E6-4/C1-ZU2S04
			AG5	E1-17/E6-5	5	E6-5/C1-ZU2S05
			AG6	E1-18/E6-6	6	E6-6/C1-ZU2S06
			FOA13	E1-1/E6-7	7	E6-7/C1-ZU1S09
			FOA14	E1-2/E6-8	8	E6-8/C1-ZU1S10
			FOA15	E1-3/E6-9	9	E6-9/C1-ZU1S11
			FOA16	E1-4/E6-10	10	E6-10/C1-ZU1S12
			FOA17	E1-5/E6-11	11	E6-11/C1-ZU1S13
			FOA18	E1-6/E6-12	12	E6-12/C1-ZU1S14
			SCV1	SCV1/E6-15	15	E6-15/C1-ZU3S05
			SCV2	SCV2/E6-16	16	E6-16/C1-ZU3S06
			SCV3	SCV3/E6-17	17	E6-17/C1-ZU3S07
			SCV4	SCV4/E6-18	18	E6-18/C1-ZU3S08
			SCV5	SCV5/E6-19	19	E6-19/C1-ZU3S09
			SCV6	SCV6/E6-20	20	E6-20/C1-ZU3S10
			SCF1	SCF1/E6-24	24	E6-24/C1-ZU4S09
			SCF2	SCF2/E6-25	25	E6-25/C1-ZU4S10
			SPV1	SPV1/E6-26	26	E6-26/C1-ZU4S11
			MFP1	MFP1/E6-27	27	E6-27/C1-ZU4S15
			TWS-200	E1-H1PWR/E6-29	29	E6-29/C1-PWR
			TWS-200	E1-H1RS/E6-30	30	E6-30/C1-ZU1RSx
			AG13	E2-1/E6-31	31	E6-31/C1-ZU3S01
			AG14	E2-2/E6-32	32	E6-32/C1-ZU3S02
			AG15	E2-3/E6-33	33	E6-33/C1-ZU3S03
			AG16	E2-4/E6-34	34	E6-34/C1-ZU3S04
			AG17	E2-5/E6-35	35	E6-35/C1-ZU4S01
			AG18	E2-6/E6-36	36	E6-36/C1-ZU4S02
			TWR1	E1-7/E6-38	38	E6-38/C1-ZU1S15
			TWR2	E2-7/E6-39	39	E6-39/C1-ZU1S16
			SYN1	SYN1/E6-65	65	E6-65/C1-SYN1
			SYN2	SYN2/E6-66	66	E6-66/C1-SYN2

A

A

B

B

C

C

D

D

CADREB2023revB



© Copyright VibroSystem inc. 2023
 VibroSystem inc. reserves the right to make changes without prior notice to improve the product.

Section: F JUNCTION BOXES (WME) INTERNAL COMPONENTS & WIRING
 Product number: VSM-CAB-MINE1-100
 Drawing number: VSM-DWG-MINE1-100
 Sheet: F5 Rev. : 1

Title: ZOOM MONITORING SYSTEM FOR PROJECT: YOUR MINING SITE
 JUNCTION BOXES DETAILS

1

2

3

4

1

2

3

4

JUNCTION BOX CONNECTIONS DETAILS						
WALLMOUNT ENCLOSURE	VSM TAG	SIZE (HxWxD) IN.	INPUT SENSOR	CABLE INPUT TAG	TERMINAL BLOCK #	CABLE OUTPUT TAG
VSM-WME24-T66	E7	24x24x8	AG7	E4-13/E7-1	1	E7-1/C1-ZU1S07
			AG8	E4-14/E7-2	2	E7-2/C1-ZU1S08
			AG9	E4-15/E7-3	3	E7-3/C1-ZU2S01
			AG10	E4-16/E7-4	4	E7-4/C1-ZU2S02
			AG11	E4-17/E7-5	5	E7-5/C1-ZU2S03
			AG12	E4-18/E7-6	6	E7-6/C1-ZU2S04
			FOA1	E4-1/E7-8	8	E7-8/C1-ZU2S05
			FOA2	E4-2/E7-9	9	E7-9/C1-ZU2S06
			FOA3	E4-3/E7-10	10	E7-10/C1-ZU2S07
			FOA4	E4-4/E7-11	11	E7-11/C1-ZU2S08
			FOA5	E4-5/E7-12	12	E7-12/C1-ZU2S09
			FOA6	E4-6/E7-13	13	E7-13/C1-ZU2S10
			FOA7	E4-7/E7-14	14	E7-14/C1-ZU2S11
			FOA8	E4-8/E7-15	15	E7-15/C1-ZU2S12
			FOA9	E4-9/E7-16	16	E7-16/C1-ZU2S13
			FOA10	E4-10/E7-17	17	E7-17/C1-ZU2S14
			FOA11	E4-11/E7-18	18	E7-18/C1-ZU2S15
			FOA12	E4-12/E7-19	19	E7-19/C1-ZU2S16
			SCV7	SCV7/E7-20	20	E7-20/C1-ZU3S11
			SCV8	SCV8/E7-21	21	E7-21/C1-ZU3S12
			SCV9	SCV9/E7-22	22	E7-22/C1-ZU3S13
			SCV10	SCV10/E7-23	23	E7-23/C1-ZU3S14
			SCV11	SCV11/E7-24	24	E7-24/C1-ZU3S15
			SCV12	SCV12/E7-25	25	E7-25/C1-ZU3S16
			SCF3	SCF3/E7-26	26	E7-26/C1-ZU4S12
			SCF4	SCF4/E7-27	27	E7-27/C1-ZU4S13
			SPV2	SPV2/E7-28	28	E7-28/C1-ZU4S14
			TWS-200	E4-H3PWR/E7-29	29	E7-29/C1-PWR
			TWS-200	E4-H3RS/E7-30	30	E7-30/C1-ZU2RSx
			AG19	E3-1/E7-31	31	E7-31/C1-ZU4S03
			AG20	E3-2/E7-32	32	E7-32/C1-ZU4S04
			AG21	E3-3/E7-33	33	E7-33/C1-ZU4S05
			AG22	E3-4/E7-34	34	E7-34/C1-ZU4S06
			AG23	E3-5/E7-35	35	E7-35/C1-ZU4S07
			AG24	E3-6/E7-36	36	E7-36/C1-ZU4S08

VSM-WME24-T66
(E7)

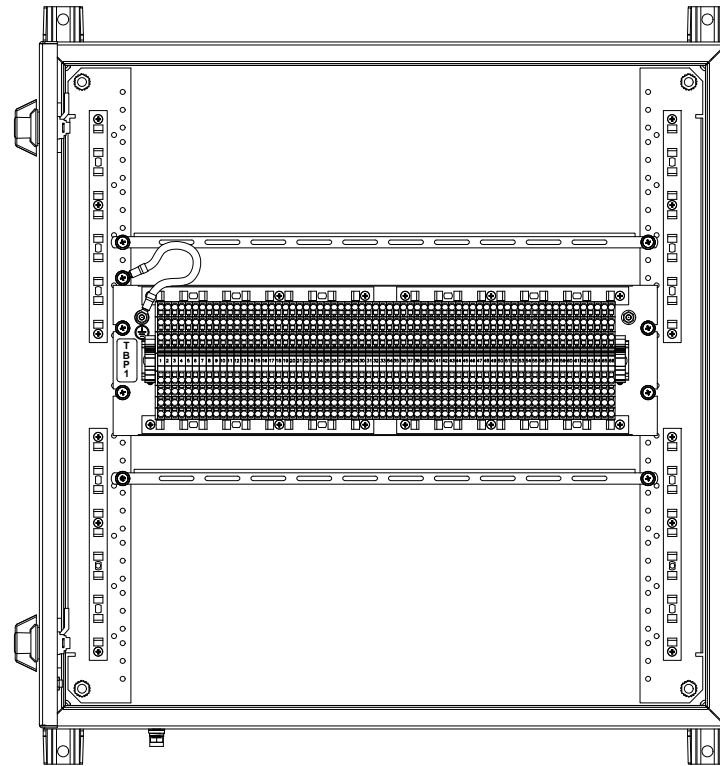

A

A

B

B

C

C

D

D

CADREB2023revB



© Copyright VibroSystM inc.2023
 VibroSystM inc. reserves the right to make changes without prior notice to improve the product.

Section: F JUNCTION BOXES (WME) INTERNAL COMPONENTS & WIRING
 Product number: VSM-CAB-MINE1-100
 Drawing number: VSM-DWG-MINE1-100
 Sheet: F6 Rev. : 1

Title: ZOOM MONITORING SYSTEM FOR PROJECT: YOUR MINING SITE
 JUNCTION BOXES DETAILS

1

2

3

4